

**Commerce Spectrum Management Advisory Committee  
Final Report  
Working Group 1 – 1695-1710 MHz Meteorological-Satellite**

**1. Executive Summary**

The Commerce Spectrum Management Advisory Committee (“CSMAC”) Working Group 1 (“WG-1”) was tasked with developing recommendations for use of the 1695-1710 MHz band for commercial services while protecting Federal meteorological earth stations from harmful interference. General instructions to the Working Groups were to “explore ways to lower the repurposing costs and/or improve or facilitate industry access while protecting federal operations from adverse impact” with instructions specific to WG-1 to improve modeling of commercial wireless network and possible reduction of exclusion zones using the Fast Track report as a baseline for federal protection requirements. Based on this guidance, WG-1 met extensively beginning in July 2012 to: (1) provide refined Long-Term Evolution (LTE) system parameters that more accurately reflect real world deployment scenarios; (2) review operating parameters of Federal systems affected by commercial operations in the 1695-1710 MHz band; (3) modify the existing simulation model used by NTIA to reach the conclusions about use/sharing of the 1695-1710 MHz band; and (4) Identify areas for further consideration of possible alternatives that may maximize availability of the spectrum in major market areas.

Significant progress was made to refine interference analysis and develop a deeper understanding of the issues and options available for maximizing access to the spectrum for commercial services while protecting incumbent federal operations in the 1695-1710 MHz and the adjacent 1675-1695 MHz bands. A technical Working Committee with both Government and industry technical experts from all of the CSMAC Working Groups was created to facilitate detailed discussions of LTE operations and parameters. The work of this committee resulted in agreed LTE technical parameters for analysis that more accurately depicts real world operation of LTE networks and how to apply the parameters to interference analysis.<sup>1</sup> The output of the technical working group includes refined UE operating parameters that more closely represent real operations including power distribution curves, base station parameters, and out-of-band emissions. NTIA updated its analyses based on the updated LTE technical parameters as well as input from WG-1 on the propagation model and analysis approach, which resulted in a significant reduction in the anticipated separation distance at which an LTE system would potentially cause harmful interference to a Meteorological Satellite receiver as compared to the exclusion zone separation distances presented in NTIA’s Fast Track report. The impact on separation distances varies from site to site based on the assumptions and conditions used in the analysis, and ranges from 21-89%. The final results of NTIA’s

---

<sup>1</sup> The final report of the Technical Committee is attached as Appendix 3

analysis are depicted in Appendix 7 of this report. These results may be further refined on a case by case basis as transition discussions begin.

The Working Group was also successful in developing a framework for sharing the band that protects incumbent federal operations while maximizing the opportunity for commercial use. The framework recognizes the need to protect the operations of both the co-channel polar orbiting satellites as well as geostationary operations in the adjacent 1675-1695 MHz band. The framework is conditioned on Protection Zones that will be based on the NTIA interference analysis and protection criteria, including aggregate Interference Power Spectral Density (IPSD) limits, to be determined for each receiver location.<sup>2</sup> The framework provides for deployment of commercial operations outside of the Protection Zones without any coordination. It also permits commercial operations within the Protection zone following a successful coordination process concluding that such commercial operations can meet specified conditions and will not cause harmful interference to ensure no loss of federal capability within the protection zones. If coordination is unsuccessful, commercial operations will not be permitted within the Protection Zone.

To facilitate coordination, the framework recognizes the need for a clear and consistent coordination process. Details of the coordination framework are outline in Appendix 1. To create this coordination process, NTIA and FCC, in conjunction with the affected federal agencies, need to establish: 1) a nationally-approved interference prediction model, associated input parameters, and distribution of aggregate IPSD limit among commercial licensees; 2) coordination procedures, including an automated process, to the extent possible, to assess if the proposed commercial network will meet the IPSD limits, to facilitate coordination allowing commercial licensee operations within the Protection Areas; and 3) procedures for implementing on-going real-time monitoring to ensure IPSD limits are not being exceeded and that commercial operations can be adjusted immediately if they are. The framework stipulates that the criteria and procedures for coordination and operation within the Protection Zones, as well as enforcement mechanisms, must still be clearly defined and subsequently codified in the FCC rules and the NTIA manual, as appropriate. Additionally, the framework calls for the establishment of a testing program to demonstrate the viability and effectiveness of proposed protection and mitigation methods before commercial licensees may begin operations within a Protection Zone.

The testing program needs to validate co-channel and adjacent channel sharing assumptions, model, and interference mitigation methods prior to the adoption of the technical rules and validate, on a site-by-site basis, the effectiveness of proposed interference mitigation methods upon completion of the auction and prior to coordinated operation within the Protection Zones. Finally, the framework recognizes that effective monitoring and enforcement mechanisms are critical to sharing in the band. Whether operating outside Protection Zones or, after successful coordination, within Protection

---

<sup>2</sup> See Appendix 2.

Zones, commercial licensees will be under an obligation not to cause harmful interference to the co-channel and adjacent channel federal sites. Commercial operators will need to provide and maintain a 24/7 point of contact should interference occur. The framework also recognizes that all federal costs related to coordination and interference resolution activities and resources must be part of the federal agencies' sharing cost estimate, fundable through the Spectrum Relocation Fund and must remain as long as federal agencies operate in the established protection zones.

The recommendations of the Working Group provide the foundation for agencies to start developing the more refined transition plans and for the FCC to start its rulemaking to implement shared use of the band. Therefore, this report and associated sharing framework include recommendations for necessary elements that remain to be addressed. These include developing the coordination, testing, monitoring, and compliance processes and associated funding criteria identified in the sharing framework. The Working Group has successfully concluded its work to refine LTE parameters and separation distance requirements for shared use of the band, and the output of the WG will inform the efforts of the FCC and NTIA-led Working Group proposed in the sharing framework.

## 2. Overview of Focus Areas for WG-1

The work group had significant participation by a broad group of both industry and federal government experts that engaged in detailed and cooperative technical discussions regarding the potential for shared use of the 1695-1710 MHz band by commercial wireless industry and federal users. Following the first meeting of WG-1 a list of areas of study and analysis was developed to guide the work.<sup>3</sup> The work can generally be broken down into three significant areas that are likely to yield the highest impact:

1) **Refinement of the interference analysis.** The majority of time of the working group was spent reviewing and understanding the analysis done for the Fast Track report and refining the analysis model inputs so that the analysis results more accurately reflected anticipated real world deployments. General areas of refinement include:

a) **LTE System Parameters** – A technical working committee was formed to provide refined LTE technical and operating parameters based on anticipated real-world deployments, including user equipment power levels and density of base station deployments. Federal and industry experts worked closely to understand the operation and deployment of LTE technology and with industry input and agreement developed LTE user equipment parameters that more closely reflect real world operation rather than

---

<sup>3</sup> See Appendix 5

the parameters used in developing NTIA's Fast Track Report. While user terminal operation parameters are the most important aspect for analysis related to Working Group 1, the Technical Committee also developed base station parameters that are necessary for analysis in the other Working Groups. The output of the technical working group includes refined UE operating parameters that more closely represent real operations including power distribution curves, base station parameters, and out-of-band emissions. The final report of the Technical Committee is included as Appendix 3.

b) Propagation Models – Differences in propagation models and application of terrain and clutter losses has a dramatic impact on results and can vary results by as much as 40 dB. Both the technical committee and the Working Group conducted extensive discussions about the most appropriate propagation model. Based on this discussion, WG-1 concluded that the ITM model was appropriate and should be used in NTIA's updated analysis. No final conclusion was reached regarding use of clutter as part of the model. However, it was determined that the analysis results would be accurate enough for the intended purpose of recommending Protection Zones and that further refinement of the interference analysis was not necessary at this time.

c) Government System Parameters – Industry and FCC liaisons requested additional, detailed information regarding the impacted federal receivers in this band as well as confirmation of the accuracy of the coordinates and other parameters used in the NTIA's Fast Track report. Given the unique nature of each installation, parameters may vary from location to location, making it difficult to get accurate information for each site. A greater understanding of the differences should be part of the verification process. The height, location and characteristics of the receive antennas will impact results. Coordinates and/or parameters for some locations have been updated since the Fast Track report and the updated information was used in the current analysis. In addition, some locations considered in the fast track report as a single location include multiple antennas that are widely spaced. With the reduction in size of separation distances from the previous analysis, it may be necessary to list each of these antennas separately to ensure adequate protection.<sup>4</sup>

Based on these changes, NTIA ran an updated analysis. For each receiver location, the analysis included at least 500 Monte Carlo trials to minimize the variance in the interference model results. The analysis results include a minimum protection distance, mean protection distance, and maximum protection distance reflecting the variation in the results. However, it must be noted that the analysis results will require validation through field testing prior to FCC rulemaking. The new analysis resulted in a significant reduction in the anticipated distance at which an LTE system would potentially cause harmful interference to a Meteorological Satellite receiver compared to the exclusion zone distances included in NTIA's Fast Track report. The impact on

---

<sup>4</sup> The WG1 effort has been focused on the 18 sites identified in the NTIA Fast Track report. Government participants have identified a limited number of additional sites that they believe warrant protection and stated that they intend to raise the issue with NTIA.

distances varies from site to site, but ranges from 21-89%. The results of NTIA's analysis are presented in Appendix 7. These results may be further refined on a case by case basis as transition discussions begin.

2) **Protection Zone versus Exclusion Zones.** There was considerable discussion in the Working Group regarding the regulatory structure necessary to protect federal receivers. NTIA's Fast Track Report relied on exclusion zones around government facilities which would have prevented potential commercial operations within the zone. Given the objective of exploring ways to maximize the potential commercial value of the band and the site customization available through LTE technology, the participants concluded that Protection Zones that allow use only after successful coordination in meeting specified conditions and without impact to federal operations would potentially allow more use of the spectrum than Exclusion Zones. The coordination approach will only work if a clearly defined and enforceable coordination mechanism is in place. Therefore, the framework included as Appendix 1 highlights the critical tenets of need to develop an appropriate structure and procedures to support coordination of proposed commercial wireless operations within the Protection Zones.

3) **Impact of GOES-R and JPSS on Continued Need for POES Receivers in the 1695-1710 MHz Band.** Launch of a new generation of satellites is scheduled to begin in 2016 with the existing POES satellites expected to be at end of life by 2030. Because the new generation satellites operate outside of 1695-1710 MHz it is anticipated that commercial operations may have greater access, both temporally and geographically, to the band in the future as the current generation is phased out. Government users emphasized the importance of protecting the receiver capabilities through the life of the existing satellites. In addition, because the band is used internationally for Met Sat operations and government users receive information from satellites operated by other countries, it is not possible to precisely define a full transition at this time.

4) **Other Methods to Maximize Commercial Use in the Top 100 Markets by Population.** Industry participants have noted that access to this band in the top 100 market areas is the most desirable. There are a relatively small number of Government receive locations in or near these market areas<sup>5</sup> that impact the availability of the spectrum for commercial wireless use. Industry has proposed examining the feasibility of relocating these receive locations to less populated areas to enable use of the spectrum for broadband services in more densely populated areas. However, to date, the feasibility and associated costs have not been studied. Aspects of this analysis include the technical feasibility of relocating the receive locations without negatively impacting capabilities of incumbent federal operations, the initial and potential recurring costs of such a relocation, funding mechanisms for the initial and recurring costs, and the timelines for meeting all federal site development regulations if relocation is deemed feasible and cost-effective. Considerations include other non-spectrum aspects, such as the need to identify and

---

<sup>5</sup> See Appendix 4

acquire new sites for relocation, required environmental studies, establishment of adequate data transfer capabilities and redundancies, contingencies to ensure adequate security of the data transmissions, and procurement and costs of ongoing operations and maintenance of the remote facilities and site interconnections.

Given the viability and cost impact of this proposal still requires detailed study, and recognizing the WG's agreement to proceed applying the required separation distances on the basis of Protection Zones as opposed to Exclusion Zones as well as the reduced size of the separation distances based on the new LTE parameters enhances the potential availability of the band for commercial operation, this option may render only limited value in further maximizing the benefit relative to the potential complexity and cost impact.

### 3. Recommendations of WG-1

#### **3.1 Recommendation 1: Adopt the framework structure in Appendix 1 for sharing the band and establish the FCC and NTIA-led Working Group to begin developing the coordination, testing, monitoring, and compliance processes, roles, and responsibilities.**

Appendix 1 proposes a framework designed to maximize shared use of the band while fully protecting incumbent federal operations in the 1695-1710 MHz and adjacent 1675-1695 MHz band. The framework permits commercial operations within the Protection Zone following a successful coordination process concluding that such commercial operations can meet specified conditions and will not cause harmful interference to ensure no loss of federal capability within the protection zones. If coordination is unsuccessful, commercial operations will not be permitted within the Protection Zone. Additionally, commercial operations are required to not cause harmful interference to the incumbent federal operations even if they are operating outside the Protection Zone. Presumed protection will be based on protection criteria, including aggregate IPSD limits to be determined for each receiver location.

The framework identifies numerous details which must be determined prior to the development and adoption of technical and service rules for commercial licensees and beginning any coordination of proposals for commercial operations within the Protection Zones. These include identifying and approving an interference prediction model and associated input parameters to be used during coordination, establishing the required testing program, and establishing the required monitoring program. The NTIA and FCC need to establish a working group to address these outstanding issues. These efforts need to begin immediately to address issues that must be resolved before rules are adopted and the auction can begin. One of these key components is analysis verification and validation testing. Additionally, funding will need to be identified to support these efforts, including testing and on-going monitoring. The output of WG-1 will inform the efforts of this new NTIA and FCC-led working group.

**3.2 Recommendation 2: Spectrum reallocated to commercial use in the 1695-1710 MHz band should be limited to mobile uplink use only.**

Through discussions between Federal and commercial entities, it became clear that spectrum in this band would be solely used for mobile transmissions. All analysis done by WG-1 was done under this assumption. As such, WG-1 recommends that NTIA work with the FCC to ensure any rules promulgated for the 1695-1710 MHz spectrum limit the use of this spectrum for commercial operators to mobile transmit.

**3.3 Recommendation 3: Consider the option of assessing the feasibility of relocating federal government receive locations or other methods to maximize commercial use of the top 100 markets by population.**

The need for spectrum for commercial services is greatest in heavily populated areas. Accordingly, demand for broadband capacity and services is greatest in these areas and therefore commands the highest interest and anticipated value.<sup>6</sup> Industry has suggested relocating federal receive sites to remote locations to allow additional commercial operations in the top 100 market areas. The feasibility of this proposal was not evaluated during the initial Fast Track study and WG-1 hasn't evaluated the feasibility either. Therefore, the feasibility and associated cost impacts will require a detailed study. Government users have noted that there are significant challenges to relocating receive locations or using remote receiver locations. However, the WG did not have sufficient time to study the feasibility of relocating receive sites to remote locations and WG-1 recommends that consideration may be given to determine the merit of conducting this analysis prior to establishing rules for an auction to establish the feasibility, anticipated costs, and estimated timelines of relocating receive sites to remote locations and backhauling data to the facility where analysis of the data is performed.

Some of the challenges that would need to be addressed when considering remote locations for receive sites include: 1) ensuring that a receive site is located in a suitable area to capture necessary data, 2) that the location is in a rural enough area to minimize the size of or need for Protection Zones in high population areas, 3) ensure that reliable power is available, 4) ensure that adequate and redundant backhaul facilities can be established to ensure highly reliable reception of data, 5) ensure that any delay in receiving raw satellite data introduced by a remote receiver is minimal and does not negatively impact the government mission and, 6) ensuring that any suitable site is able to meet applicable environmental statutory regulatory requirements to build-out such a facility. Additionally, the anticipated initial installation and ongoing operations and maintenance costs will need to be identified along with the estimated timeline for relocating the sites. If this option is going to be considered, the feasibility analysis must be completed before the development of the FCC's rules. The costs of conducting this analysis will need to be accounted for in the overall cost assessment

---

<sup>6</sup> See Appendix 4

#### **4. Conclusion**

WG-1 Recommends that the NTIA adopt the Framework proposed as Recommendation 1 along with the other recommendations. This Framework provides a solid foundation to develop the details of shared federal/non-federal use of the 1695-1710 MHz band. The NTIA and FCC should also work together to begin developing the operational, coordination, testing, monitoring and compliance rules, processes, roles and responsibilities necessary for successful implementation of shared use of the band.

#### **5. Technical Appendices**

Appendix 1: Framework for Sharing

Appendix 2: ISPD Calculation Method

Appendix 3: Report of the Technical Committee

Appendix 4: Top 100 Markets Impacted

Appendix 5: Study Areas

Appendix 6: GOES and POES Overview and Characteristics

Appendix 7: Results of Protection Zone Analysis

Appendix 8: List of Participants



# Appendix 1

## A Framework for Federal Spectrum Sharing Rules for the 1695-1710 MHz Band

### 1) Protection of Federal Government Receiver Sites in the 1695-1710 MHz Band.

- Federal Government entities operate meteorological satellite receivers in the 1695-1710 MHz band and the adjacent 1675-1695 MHz, nationwide. Commercial wireless licensees must protect these receive sites from in-band and adjacent band interference in order to enable the impacted federal agencies to share the 1695-1710 MHz band without loss of capability. The Federal Government is proposing a combination of Protection Zones in conjunction with other protection criteria, including Interference Power Spectral Density (IPSD) Limits, to protect the meteorological satellite receivers. Commercial wireless licensees shall protect the receive sites from interference by restricting their operations from any locations their operations could potentially cause interference to government operations at the receive sites indicated in the Table 1 from commercial mobile, fixed, and portable stations transmitting in the 1695-1710 MHz band. Operation outside of the protection zones is presumed to be acceptable unless demonstrated otherwise. Commercial wireless licensees may be permitted to operate mobile stations in the protection zones if certain conditions can be met, including:
  - a) Commercial wireless licensees shall coordinate any desired entry into the protection zones and demonstrate that their operations will not cause harmful interference in order to allow the affected federal agencies to assess the feasibility of entry resulting in a go/no-go determination.
  - b) NTIA and the FCC, in coordination with the affected federal agencies, will establish–
    - 1) A nationally-approved interference prediction model, associated input parameters, and acceptable methods for distribution of the aggregate IPSD limits among commercial wireless licensees.
    - 2) Coordination procedures, including an automated process to assess if the proposed commercial wireless network will meet the IPSD limits, to facilitate coordination of proposed commercial wireless operations within the protection areas.
    - 3) On-going real-time monitoring to ensure the IPSD limits are not being exceeded.
  - c) Criteria and procedures for coordination and operation within the protected zones, as well as enforcement mechanisms, must be clearly defined and codified in the FCC rules and the NTIA manual, as well other forms of agreements (e.g., NDAs, MOUs), as appropriate.
  - d) All federal costs related to coordination activities and resources shall be part of the federal agencies' sharing cost estimate and fundable through the SRF (e.g., dedicated staff needed for coordination and analysis) and shall remain in place for as long federal agencies operate in the protection zones.
  - e) Coordination within the protection zones shall address both in-band and adjacent band interference issues.

# Appendix 1

- f) If federal users at a protected facility receive harmful interference, commercial wireless licensees will, upon notification, immediately cease operation on the channels and in the area of concern until the interference is resolved through the established NTIA and FCC facilitated processes.

## 2) Definitions Framework

**Protection Zone** – A specified radius  $r_{pz}$  or otherwise defined area around a protected receive site within which commercial wireless mobile transmitters shall protect federal government receivers from interference in the 1695-1710 MHz and adjacent 1675-1695 MHz band based on specified protection criteria, including Interference Power Spectral Density (IPSD) Limits. Commercial wireless licensees shall coordinate desired entry into the protection zones and must fully demonstrate viability and effectiveness of proposed protection/interference mitigation methods before being able to operate within the zones.

## 3) Key Components to Consider when Developing Coordination Procedures for Spectrum Sharing in the 1695-1710 MHz Band

- The key components to consider when developing the coordination procedures for spectrum sharing in the 1695-1710 MHz band include, but are not limited to:
  - a) Testing program – A testing program is required to demonstrate the viability and effectiveness of proposed protection/mitigation methods before commercial wireless licensees begin operations within Protected Zones. The testing program shall:
    - Validate co-channel and adjacent channel sharing assumptions, models, and interference mitigation methods
    - Utilize mutual agreement and validation of proposed validation and verification methods
    - Clearly define which parties coordinate and approve verification test plans and schedules
    - Be adaptable for future or potentially changing satellite and commercial wireless operational configurations
  - b) Real-time monitoring - An agreed compliance monitoring mechanism must be established to ensure that the IPSD limits are not being exceeded. The monitoring shall:
    - Aid in technical assessment of current practices and procedures
    - Maintain adherence to the IPSD limits at the face of each federal system antenna, which commercial systems must respect as a backstop to coordination.
      - Monitoring reveals and identifies levels of interference
      - Monitoring establishes a likely source
  - c) Interference resolution protocols – An agreed mechanism must be established to expeditiously identify the causes of interference and to resolve interference events when required. Despite best efforts in coordination and plans to operate within

# Appendix 1

agreed-upon interference protection/mitigation criteria, some harmful interference may occur.

- d) Compliance and enforcement – An agreed upon mechanism must be established to ensure that commercial wireless licensees cease operations in the band, in the area of concern, until interference sources are identified and resolved.

**TABLE 1 – Earth Station Receive Locations<sup>1</sup>**

Station Type	Earth Station Name	Latitude	Longitude	Protection Zone Size (km)			15 MHz Case Population Affected	
				5 MHz	10 MHz	15 MHz	2010 Census Pops Impacted	2010 Census Percentage of US Pops
POES/GOES	Wallops Island, VA	375645N	0752745W	29	30	30	20,216	0.01%
POES/GOES	Fairbanks, AK	644814N	1475234W	81	84	81	97,024	0.04%
POES/GOES	Suitland, MD	385107N	0765613W	91	91	91	7,103,370	3.08%
POES/GOES	Miami, FL	254700N	0801900W	46	46	46	3,445,628	1.49%
POES/GOES	Ford Island, Pearl Harbor HI	212212N	1575744W	25	25	25	838,735	0.36%
POES/GOES	Sioux Falls, SD	434409N	0963733W	36	40	42	201,568	0.09%
POES/GOES	Elmendorf Air Force Base, AK	610859N	1492812W	14	14	14	291,826	0.13%
POES/GOES	Anderson Air Force Base, GU	133452N	1445528E	42	42	42	-	0.00%
POES/GOES	Monterey, CA	363600N	1215400W	88	85	85	1,854,802	0.80%
POES/GOES	Stennis Space Center, MI	302359N	0893559W	58	58	58	562,810	0.24%
POES/GOES	Twenty-Nine-Palms, CA	341746N	1160944W	80	80	80	505,521	0.22%
POES/GOES	Yuma, AZ	323924N	1143622W	95	95	95	304,667	0.13%
GOES Only	Cincinnati, OH	390608N	0843036W	32	32	32	1,163,095	0.50%
GOES Only	Rock Island, IL	413104N	0903346W	14	10	19	272,245	0.12%
GOES Only	St. Louis, MO	383526N	0901225W	27	34	29	1,367,129	0.59%
GOES Only	Vicksburg, MS	322123N	0905129W	16	14	15	27,566	0.01%
GOES Only	Omaha, NE	412056N	0957534W	30	30	30	514,512	0.22%
GOES Only	Sacramento, CA	383550N	1213234W	55	55	55	2,081,393	0.90%
Totals:							20,652,107	8.96%

<sup>1</sup> The 2010 Fast Track Report used 2000 Census data for the US population. This report uses 2010 Census data, resulting in slightly different POPs percentages. For example, the POPs covered by the Suitland Protection zone actually increased by one one-hundred of a percent despite the reduction in size of the zone.

# Appendix 2

## Calculation of IPSD

The interference thresholds ( $I_T$ ) used in assessing compatibility between Federal and wireless broadband systems will be determined using Equation 1:

$$I_T = I/N + N \quad (1)$$

where:

- I/N: Maximum permissible interference-to-noise ratio at the receiver intermediate frequency (IF) output (detector input) necessary to maintain acceptable performance criteria (dB)
- N: Receiver inherent noise level at the receiver IF output referred to the receiver input (dBm)

For a known receiver IF bandwidth and receiver noise figure (NF) or system noise temperature, the receiver inherent noise level is given by:

$$N = -114 \text{ [dBm]} + 10 \log(B_{IF} \text{ [MHz]}) + NF \quad (2)$$

$$N = kT_s B_{IF} = -198.6 \text{ [dBm/K/Hz]} + 10 \log(T_s \text{ [K]}) + 10 \log(B_{IF} \text{ [Hz]}) \quad (3)$$

where:

- $B_{IF}$ : Receiver IF bandwidth (see equations for units)
- NF: Receiver noise figure (dB)
- $k$ : Boltzmann's constant,  $1.38 \times 10^{-23}$  (Watts/K/Hz)
- $T_s$ : System noise temperature (Kelvin)

### Meteorological-Satellite Earth Station Receivers

The analysis will use an I/N of -10 dB, corresponding to a 0.4 dB increase in the receiver noise to establish the interference threshold for meteorological-satellite earth station receivers.

### **Reference 1: Federal receiver coexistence requirements for 1695-1710 MHz<sup>1</sup>**

---

<sup>1</sup> CSMAC WG 1 Doc. 2 "Electromagnetic Compatibility Analysis in 1605-1710 MHz Band," p. 5-6.

## Appendix 3

# Baseline LTE Uplink Characteristics

---

This document reflects the consensus of the LTE Technical Characteristics group of the CSMAC Working Groups. Participants include:

### **WG-1 Co-Chairs**

Ivan Navarro – DOC/NOAA

Steve Sharkey – T-Mobile

### **Industry Representatives**

Maqbool Aliani – Lightsquared

Kumar Balachandran – Ericsson

Mike Chartier – Intel

Doug Duet – AT&T

Tom Dombrowsky – Wiley Rein

Rick Engelman – Sprint

Paul Frew – RIM

John Graybeal – Cisco

Alexander Gerdenitsch – Motorola Mobility

Arunabha Ghosh – AT&T

Frank Jager – Verizon

Jorgen Karlsson – Ericsson

Rob Kubik – Samsung

Milap Majmundar – AT&T

Joe Marx – AT&T

Mark McHenry – Shared Spectrum

Prakash Moorut – Nokia Siemens Networks

Mark Racek – Ericsson

Sanyogita Shyamsunder – Verizon

Doug Smith – Lightsquared

David Steer – RIM

Neeti Tandon – AT&T

Nelson Ueng – T-Mobile

Patrick Welsh – Verizon

Christopher Wieczorek – T-Mobile

Stephen Wilkus – Alcatel-Lucent

Ken Zdunek – Roberson & Associates

### **NTIA Liaisons**

Ed Drucella

John Hunter

### **Government Representatives**

Lloyd Apirian – Alion Science

Lawrence Crippen – Alion Science

David Greenberg – Alion Science

Jason M Greene – Alion Science

Robert Martin – Alion Science

Robert L. Higginbotham – CIV DISA DSO

Gerald Hurt – Consultant to Exelis, Inc.

Daniel Jablonski – JHU Applied Physic Lab

Peter G. Kim – Aerospace Corp

Lawrence Lambert – Exelis, Inc.

Paul McKenna – NTIA/ITS

Albert 'Buzz' Merrill - Aerospace

Pierre Missud – ATDI

Eric Nelson – NTIA/ITS

Emil Olbrich – NIST

Thomas Shanholtz – Exelis, Inc.

O. Alden Smith – CTR DISA DSO; Scitor Corp.

Martin Rais – ATDI

Brian Wright - DOI

### **FCC Liaisons**

Navid Golshahi

Michael Ha

Chris Helzer

Robert Pavlak

Robert Weller

Janet Young

## Appendix 3

# Baseline LTE Uplink Characteristics

---

## For use in Interference Analysis for Protection of Federal Operations in the 1695-1710 and 1755-1850 MHz Bands, including adjacent bands

### Introduction

The information regarding LTE Uplink Characteristics is intended for use in general analysis of the potential for interference between commercial LTE operations and Federal Government operations in the 1755-1850 MHz band. The information represents a collaborative effort between industry and government representative experts to agree on LTE parameters that are closer to realistic operational parameters than have been used in past analysis. However, because these parameters will be used in general analysis, it is not possible to fully capture the parameters that will be observed in an actual deployment, which will vary by carrier implementation and site specific geography. In order to provide a uniform set of information to apply in a wide variety of analysis, a number of simplifying assumptions have been made that may continue to result in analysis showing a greater level of interference that would actually occur. These include, but are not limited to, the assumptions being based on 100% loading rather than a more realistic loading level and use of propagation curves that may result in higher calculated power. In addition, because the transmit power and interference potential of a UE device is highly dependent on the UE distance to a base station, developing and applying UE information that is uncorrelated to interfering path is likely to overestimate the amount of interference. None-the-less, given the difficulty of developing and running a fully correlated model, the Technical Group participants agreed that it is reasonable to proceed with uncorrelated values in order to develop a general understanding of the interference potential given limited time and resources. Analysis based on this information will serve as useful guidance in understanding the potential for systems to coexist and the potential for interference. However, site specific coordination will be necessary to maximize efficient use of the spectrum.

### User Equipment (UE) Transmit Characteristics

#### Cumulative Distribution Function (CDF) of Total EIRP per Scheduled User Equipment

- Assumptions for generation of CDF data:
  - LTE Frequency Division Duplex (FDD) system
  - 10 MHz LTE Bandwidth
  - 100% system loading at LTE Base Station (eNodeB)
    - All Physical Resource Blocks (PRB) are occupied at all times
  - 100% outdoor UE distribution
  - $P_0 = -90$  dBm and  $\alpha = 0.8$  for UL Power Control (urban/suburban/rural)
  - Proportional fair algorithm for LTE Scheduler
  - Full-buffer traffic model (i.e. All UEs have data in their Radio Link Control (RLC) layer buffer at all times)

# Appendix 3

- Graphical CDF Data

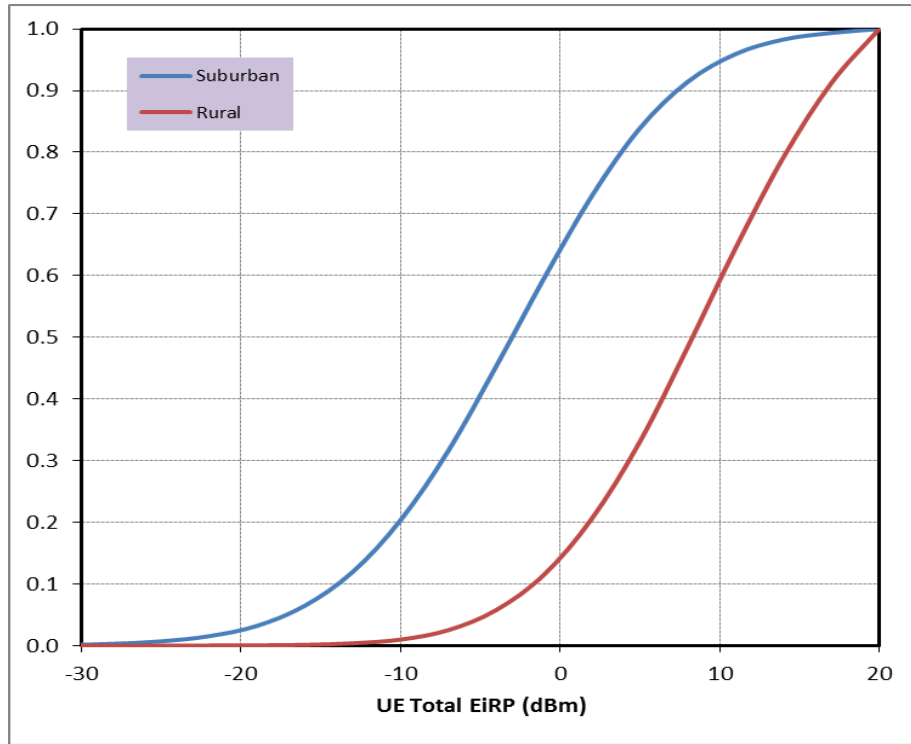

## Appendix 3

- Tabulated CDF Data

UE EIRP (dBm)	Urban/Suburban (1.732 Km ISD) (6 UE scheduled/TTI/sector)		Rural (7 Km ISD) (6 UE scheduled/TTI/sector)	
	PDF	CDF	PDF	CDF
-40	0.0000	0.0000	0.0000	0.0000
-37	0.0001	0.0001	0.0000	0.0000
-34	0.0002	0.0003	0.0000	0.0000
-31	0.0008	0.0011	0.0000	0.0000
-28	0.0020	0.0031	0.0000	0.0000
-25	0.0040	0.0071	0.0000	0.0000
-22	0.0083	0.0154	0.0002	0.0002
-19	0.0166	0.0320	0.0004	0.0006
-16	0.0327	0.0647	0.0007	0.0013
-13	0.0547	0.1194	0.0026	0.0039
-10	0.0839	0.2033	0.0060	0.0099
-7	0.1128	0.3160	0.0153	0.0252
-4	0.1370	0.4530	0.0325	0.0577
-1	0.1429	0.5959	0.0575	0.1152
2	0.1338	0.7297	0.0911	0.2062
5	0.1094	0.8390	0.1245	0.3307
8	0.0753	0.9143	0.1536	0.4843
11	0.0450	0.9594	0.1605	0.6448
14	0.0236	0.9830	0.1473	0.7920
17	0.0106	0.9936	0.1203	0.9123
20	0.0064	1.0000	0.0877	1.0000

### Assumed Number of Scheduled (transmitting) UE per Sector

- Assume Physical Downlink Control Channel (PDCCH) = 6 is typical for a 10 MHz LTE Channel
  - PDCCH contains Downlink Control Information (DCI) blocks, which provide downlink and uplink resource allocations, and power control commands for UEs
  - Use UEs per sector (i.e. the number of simultaneously transmitting UEs is 6 per sector or 18 per eNodeB, for a 10 MHz Channel)
  - 100 % of uplink resources (PRBs) are equally distributed among transmitting UEs in each sector
- Randomly assign power in accordance with UE power CDF for each independent Monte-Carlo analysis trial
- The PDCCH value and corresponding number of UE should be adjusted based on the LTE channel bandwidth:

PDCCH Value / Channel Bandwidth			
5 MHz	10 MHz	15 MHz	20 MHz
PDCCH = 3	PDCCH = 6	PDCCH = 9	PDCCH = 12



# Appendix 3

## Assumed Inter-Site Distance (ISD) for Generic LTE eNodeB Deployment

- Use concentric circles centered around metropolitan area unless other site specific assumptions are agreed upon.
- Urban/suburban area assumed to be 30 km radius with rural area covering outer circle up to 100 km, unless other site specific assumptions are mutually agreed upon
- Surrounding rural deployment may be adjusted by mutual agreement if and when there is more than one urban/suburban area within 100km of the site being analyzed

Deployment	ISD	eNodeB Antenna Height	UE Antenna Height
Urban/Suburban (r <= 30 km)	1.732 km	30 m	1.5 m
Rural (U/S Edge < r <= 100 km)	7 km	45 m	1.5 m

## Requirements for Unwanted Emissions

LTE specification defines requirements for two separate kinds of unwanted emissions, with those for spurious emissions being the more stringent. In addition to these minimum requirements, additional spectrum emission requirements defined in the 3GPP standard must be fulfilled for a specific deployment scenario such as intra-band contiguous Carrier Aggregation, cell handover, UL-MIMO, etc.

### 1) Out-of-Band (OOB) Emissions

#### a) Spectrum Emissions Mask (SEM)

- OOB specification is defined with respect to the edge of the occupied bandwidth and it is absolute value
- The 3GPP defines standard identifies two resolution measurement bandwidths (30 kHz and 1 MHz). For example, -15 dBm/30 kHz for  $\Delta f_{OOB} \pm 0-1$  in 5 MHz can be converted to 1 MHz bandwidth resolution results in a limit of 0.23 dBm/1MHz
- For frequencies greater than ( $\Delta f_{OOB}$ ) as specified in Table below for Band Class 4, the spurious emissions requirements are applicable

Spectrum Emission Limit (dBm)/ Channel Bandwidth							
$\Delta f_{OOB}$ (MHz)	1.4 MHz	3.0 MHz	5 MHz	10 MHz	15 MHz	20 MHz	Measurement Bandwidth
$\pm 0-1$	-10 (5.23)	-13 (2.23)	-15 (0.23)	-18 (-2.77)	-20 (-4.77)	-21 (-5.77)	30 kHz (1 MHz)
$\pm 1-2.5$	-13	-13	-13	-13	-13	-13	1 MHz
$\pm 2.5-2.8$	-25	-13	-13	-13	-13	-13	1 MHz
$\pm 2.8-5$		-13	-13	-13	-13	-13	1 MHz
$\pm 5-6$		-25	-13	-13	-13	-13	1 MHz
$\pm 6-10$			-25	-13	-13	-13	1 MHz
$\pm 10-15$				-25	-13	-13	1 MHz
$\pm 15-20$					-25	-13	1 MHz
$\pm 20-25$						-25	1 MHz

## Appendix 3

### 2) Adjacent Channel Leakage Ratio (ACLR)

- ACLR is the ratio of the filtered mean power centered on the assigned channel frequency to the filtered mean power centered on an adjacent channel frequency at nominal channel spacing
- Defines ACLR requirements for two scenarios for an adjacent LTE (Evolved Universal Terrestrial Radio Access (E-UTRA)) channels and/or UMTS channels
- The minimum requirement of ACLR for LTE is specified, as follows:

	Channel bandwidth / E-UTRA <sub>ACLR1</sub> / Measurement Bandwidth					
	1.4 MHz	3.0 MHz	5 MHz	10 MHz	15 MHz	20 MHz
E-UTRA <sub>ACLR1</sub>	30 dB	30 dB	30 dB	30 dB	30 dB	30 dB
E-UTRA channel Measurement bandwidth	1.08 MHz	2.7 MHz	4.5 MHz	9.0 MHz	13.5 MHz	18 MHz
Adjacent channel center frequency offset (in MHz)	+1.4 / -1.4	+3.0 / -3.0	+5 / -5	+10 / -10	+15 / -15	+20 / -20

### 3) Spurious Emissions

- Occurs well outside the bandwidth necessary for transmission and may arise from a large variety of unwanted transmitter effects such as harmonic emission, parasitic emissions, intermodulation products and frequency conversion products, but exclude OOB emissions unless otherwise stated
- This value would be used for all the blank spaces in SEM mask

Frequency Range	Maximum Level	Measurement Bandwidth	Notes
$9 \text{ kHz} \leq f < 150 \text{ kHz}$	-36 dBm (-6 dBm)	1 kHz (1 MHz)	
$150 \text{ kHz} \leq f < 30 \text{ MHz}$	-36 dBm (-16 dBm)	10 kHz (1 MHz)	
$30 \text{ MHz} \leq f < 1000 \text{ MHz}$	-36 dBm (-26 dBm)	100 kHz (1 MHz)	
$1 \text{ GHz} \leq f < 12.75 \text{ GHz}$	-30 dBm	1 MHz	
$12.75 \text{ GHz} \leq f < 19 \text{ GHz}$	-30 dBm	1 MHz	Note 1
Note 1: Applies for Band 22, Band 42 and Band 43			

# Appendix 3

## LTE Base Station Receive Characteristics

This table endeavors herein to provide an overview of Base Station Receiver characteristics established by international standards. While the characteristics can be used in a preliminary analysis of the potential for interference from Government operations to commercial operations there are numerous implementation specific methods that a carrier can deploy to significantly impact the potential for interference. Examples include, but are not limited to antenna down tilt, antenna orientation, power control to improve link margin, temporal use of specific channels to avoid using channels during periods when interference is likely, and use of natural terrain to provide shielding. Annex 1 provides a more detailed discussion of the potential impact of antenna down tilt and orientation. Because these features are implementation specific it is difficult to include them as part of a general analysis and specific features should not be included as part of final rules. While a general analysis may be useful in determining the overall viability as to whether some form of sharing is possible, rules should not include a defined exclusion or coordination zone that precludes commercial deployments in a given area based on the potential for interference to the commercial operation. Instead, as much information as possible regarding the government operations should be provided, thus allowing the commercial licensee to determine the most effective method to mitigate interference.

- LTE (FDD) Base Station Receiver Characteristics

Parameter	Base Station	
Receiver Channel Bandwidth (MHz)	1.4, 3, 5, 10, 15 and 20 With signal bandwidths of 1.08, 2.7, 4.5, 9, 13.5 and 18 MHz	
Adjacent Channel Selectivity (ACS)	Channel BW Wide Area BS	Wide Area BS Wanted Signal Mean Power (dBm)
	1.4 MHz 3 MHz 5 MHz 10 MHz 15 MHz 20 MHz	-95.8 ( $P_{\text{REFSENS}} + 11\text{dB}$ ) -95.0 ( $P_{\text{REFSENS}} + 8\text{dB}$ ) -95.5 ( $P_{\text{REFSENS}} + 6\text{dB}$ ) -95.5 ( $P_{\text{REFSENS}} + 6\text{dB}$ ) -95.5 ( $P_{\text{REFSENS}} + 6\text{dB}$ ) -95.5 $P_{\text{REFSENS}} + 6\text{dB}$
	Reference TS 36.104 Table 7.5.1-3	Interfering signal mean power: -52 dBm <sup>i</sup>
	Channel BW Local Area BS	Local Area BS Wanted Signal Mean Power (dBm)

## Appendix 3

Parameter	Base Station	
	1.4 MHz 3 MHz 5 MHz 10 MHz 15 MHz 20 MHz  Reference TS 36.104 Table 7.5.1-4	-87.8 ( $P_{\text{REFSENS}} + 11\text{dB}$ ) -87.0 ( $P_{\text{REFSENS}} + 8\text{dB}$ ) -87.5 ( $P_{\text{REFSENS}} + 6\text{dB}$ ) -87.5 ( $P_{\text{REFSENS}} + 6\text{dB}$ ) -87.5 ( $P_{\text{REFSENS}} + 6\text{dB}$ ) -87.5 ( $P_{\text{REFSENS}} + 6\text{dB}$ )  Interfering signal mean power: -44 dBm <sup>ii</sup>
Noise Figure (dB)	5	
Reference Sensitivity (dBm) $P_{\text{REFSENS}}$ for Wide Area BS <sup>iii</sup>	1.4 MHz 3 MHz 5 MHz 10 MHz 15 MHz 20 MHz	-106.8 -103.0 -101.5 -101.5 -101.5 -101.5
Reference Sensitivity (dBm) $P_{\text{REFSENS}}$ for Local Area BS	1.4 MHz 3 MHz 5 MHz 10 MHz 15 MHz 20 MHz	-98.8 -95.0 -93.5 -93.5 -93.5 -93.5
Antenna Gain (Mainbeam) (dBi) <sup>iv, v, vi</sup>	18	
Azimuth Off-Axis Antenna Pattern (dBi as a function of off-axis angle in degrees)	ITU-R Recommendation F.1336-3 with an elevation 3 dB beamwidth of 10 degrees, $k=0.2$ and the equations in Section 3.2 <sup>vi</sup>	
Elevation Off-Axis Antenna Pattern (dBi as a function of off-axis angle in degrees)	ITU-R Recommendation F.1336-3 with an elevation 3 dB beamwidth of 10 degrees, $k=0.2$ and the equations in Section 3.2 <sup>vi</sup>	
Antenna Polarization	Linear	
Antenna Height (meters) <sup>1</sup>	30 (Urban/Suburban) 15 to 60 (Rural)	
Antenna Azimuth 3 dB Beamwidth (degrees) <sup>2</sup>	70	
Antenna Down Tilt Angle (degrees)	3	
Cable, Insertion, or Other Losses (dB)	2	
Interference Criterion	1dB desense. This translates into a maximum interference = Noise floor - 5.87 dB ( $I/N = \sim -6\text{dB}$ ).	
<p>Note 1: For single entry analysis the maximum antenna height of 45 meters for base stations will be used for rural. For aggregate analysis antenna heights will be varied between the minimum and maximum values shown in the table.</p> <p>Note 2: A base station typically has three sectors each 120 degrees wide.</p>		

## Appendix 3

# Appendix 3

## ANNEX

### Example: Interference Mitigation via Antenna Downtilting and Antenna Azimuth Orientation

Commercial cellular deployments do regularly take into account interference considerations. Even inter-cell interference within the same service provider network typically results in finite antenna downtilt, particularly for systems with full spectral reuse (i.e., 3G, 4G). Also in the commercial cellular world there exist numerous instances where adjacent band and other interference scenarios have been successfully mitigated via proper RF design (e.g., between service providers in adjacent spectrum, etc).

To illustrate the potentially significant impact of these antenna techniques on the interference issues, we evaluate two representative commercial base station antennas from CommScope/Andrew in the discussion below. Depending on the Federal Government systems involved, different assumptions might be appropriate.

- Andrew HBX-6516DS-T0M: 18 dBi max gain (along the main beam or “bore sight” direction), 65° horizontal beamwidth, 0° electrical downtilt, 7.1° vertical beamwidth.
- Andrew HBX-9016DS-T0M: 18.3 dBi max gain, 90° horizontal beamwidth, 0° electrical downtilt, 4.8° vertical beamwidth.

Using these antennas, and orienting them with a 60° azimuthal offset from the Federal Government system direction, the gain reductions for various reasonable antenna downtilts are calculated (in the table, the gain reductions listed below are with respect to the max ~18dBi gain of these antennas). The displayed gain reductions as a function of the downtilt angles are for the case of an interferer at the horizon. Note that an interference source like JTRS may be at an elevation (e.g., the WG-5 draft calculation assumed 10,000 feet), which would result in higher gain reductions.

Antenna	Gain reduction from 60° azimuthal orientation	Gain reduction from 4° vertical downtilt [Total reduction from azimuth + downtilt]	Gain reduction from 6° vertical downtilt [Total reduction from azimuth + downtilt]	Gain reduction from 8° vertical downtilt [Total reduction from azimuth + downtilt]
Andrew HBX-6516DS-T0M	8.6 dB	2.8 dB [11.4 dB]	7.4 dB [16.0 dB]	16.3 db [24.9 dB]
Andrew HBX-9016DS-T0M	6.3 dB	8.7 dB [15.0 dB]	26.9 dB [33.2 dB]	24.1 dB [30.4 dB]

As can be seen, total gain reductions (summing the reductions due to azimuthal orientation plus those from vertical downtilt) can be very large, anywhere from 11.4 to 30.4 dB – assuming the Federal Government interfering transmitter is at the horizon in our example.

---

Notes:

## Appendix 3

- 
- <sup>i</sup> This interfering signal mean power is for a wanted signal mean power at  $P_{\text{REFSENS}} + x\text{dB}$  (where  $x=6\text{dB}$  for 3-20MHz channels and 11dB for 1.4MHz channel). One way to interpret this spec is that this is the maximum interference level for  $x\text{dB}$  desense criterion. For instance, if 1dB desense is used in the coexistence studies, a conversion can be done to adjust for the lower desense criterion. For example, if adjacent channel selectivity is specified as -52dBm and wanted signal mean power is  $P_{\text{REFSENS}} + 6\text{dB}$ , the level can be adjusted by 11dB for the smaller sensitivity degradation allowed giving  $-52-11 = -63\text{dBm}$ :
- 1 dB desense: maximum interference = Noise floor - 5.87 dB
- <sup>ii</sup> Same as in footnote i, interfering signal mean power can be adjusted for 1dB desense if this criterion is used in the coexistence studies. For example, in the case of wanted signal mean power at  $P_{\text{REFSENS}} + 6\text{dB}$ , the level can be adjusted by 11dB for the smaller sensitivity degradation allowed giving  $-44-11 = -55\text{dBm}$ .
- <sup>iii</sup> See 3GPP TS 36.104, §7.2.  $P_{\text{REFSENS}}$  is the power level of a single instance of the reference measurement channel. This requirement shall be met for each consecutive application of a single instance of FRC A1-3 mapped to disjoint frequency ranges with a width of 25 resource blocks each.
- <sup>iv</sup> Base station antennas, both receive and transmit, typically have strongly angle-dependent gain characteristics characterized by a horizontal and vertical beamwidth. The gain value listed here corresponds to the maximum gain corresponding to the main lobe of the antenna.
- <sup>v</sup> Assuming full bore-sight gain of the LTE BS receive antenna (18dBi) may not reflect interference mitigation techniques as would be naturally deployed. Significant interference mitigation can be achieved via several factors, which are standard in the industry: e.g., antenna downtilts (point below the horizon, achieved by either mechanical and/or electrical means), antenna azimuth orientation (orient away from the interferer), and use of available terrain (where it exists) for additional refraction loss, etc. This needs to be taken into account when doing interference studies. The antenna techniques are further discussed in the Annex.
- <sup>6</sup> See Annex 8 of ITU-R Recommendation F.1336-3, which observes that the recommended equations for antenna gains often do not accurately reflect the gains of actual antennas – particularly with regard to the side lobes, as indicated in Figs 24 to 27 in Annex 8. This should be taken account when considering interference in directions far from the main antenna lobe.

## **Appendix 4**

### **Map of Top 100 Cellular Market Areas Markets Impacted**



NTIA Identified Exclusion Zones for 1695-1710 MHz for 100 Largest Markets  
(not including Honolulu, HI)

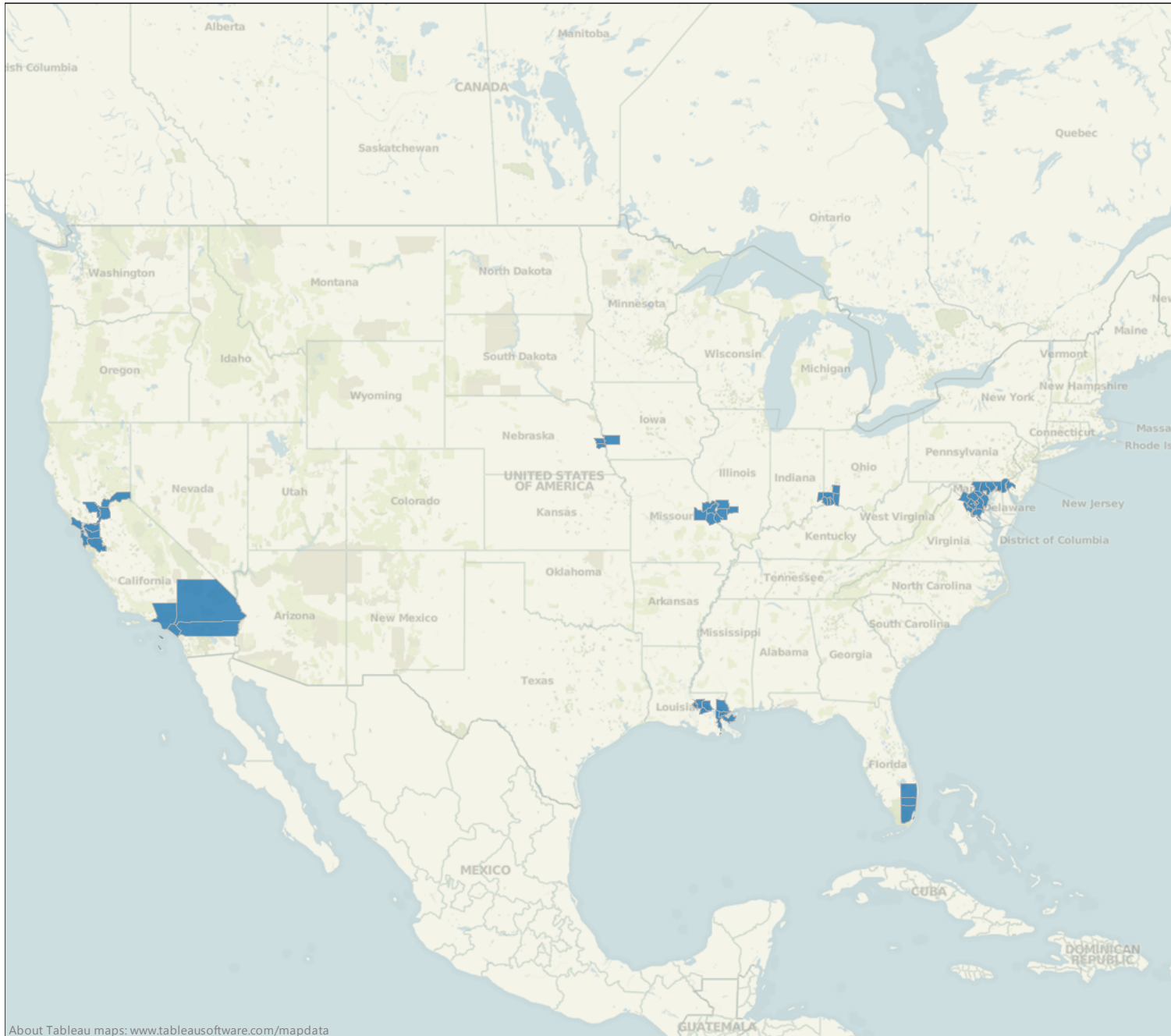

About Tableau maps: [www.tableausoftware.com/mapdata](http://www.tableausoftware.com/mapdata)

Map based on Longitude (generated) and Latitude (generated). Details are shown for STATE, COUNTY and CMA. The view is filtered on CMA and Name (cma names (cmanames.xls)) as an attribute. The CMA filter keeps 100 of 735 members. The Name (cma names (cmanames.xls)) as an attribute filter keeps 15 members.

# Appendix 5

## Areas of Analysis

- 1) Interference Calculations/Inputs impacting Exclusion Zones
  - a. Satellite Protection Requirement – Review whether the -10 dB I/N is the appropriate protection requirement.
  - b. Satellite Operational Requirement – Evaluate minimum look angle assumption and protection requirements for tracking protection – Need additional information on technical requirements.
  - c. LTE handset/system power levels – Provide appropriate handset operating and power information to allow use of realistic parameters for the interference analysis. Can signaling in LTE adjust mobile stations output power levels based on location?
  - d. LTE handset emission spectrum representation
  - e. LTE handset deployment and distribution – number of handsets per sector; whether “buffer zones” exist around earth station sites that are owned by the earth station operator, who can restrict on-site handset operation. LTE can support different spectrum in different bands – Can base stations in proximity to an Earth station command mobiles out of 1675-1710 MHz within a “buffer zone”?
  - f. Timing of LTE deployment and customer use – Based on timing of expected auction and system deployment (licensing expected Feb. 2015 and deployment at least 1-2 years), consider any impact on interference power into satellite receivers and any relevant considerations with phasing out of older satellites.
  - g. Terrain/environmental Considerations – Review terrain/environmental factors used in ITM analysis
  - h. Antenna Polarization – NOAA to provide information on antenna polarization and the receiver hardware
  - i. Additional Details of Satellite Operations – NOAA to provide additional details, including modulation, data rates and error correction.
  - j. Satellite receiver selectivity representation: (1) criteria for Earth station front end amplifier desensitization; (2) operation and signal threshold for tracking receiver on full motion Earth stations; and (3) bandwidth and parameters necessary to determine interference to the desired downlink signal
  - k. Determine the maximum allowable interference power density at the face of the Earth station.
- 2) Filtering to Improve Performance –
  - a. Evaluate potential for improving adjacent channel interference through improved receiver filtering. Need details of channel bandwidth versus receiver bandwidth for each system.

## Appendix 5

- b. Evaluate mobile transmit filtering and potential for improving adjacent band interference.
- 3) Feasibility of Relocating Satellite Receive Locations to Less Densely Populated Areas – Consideration include continued ability to receive necessary information, reliability of any backhaul solutions, cost and operational factors
- 4) Feasibility of consolidating some of the exclusion zones that are close to each other
- 5) Further Understand Continued Importance of POES during Transition to New JPSS – Do opportunities exist for reducing POES exclusion zones as JPSS come on line?
- 6) Temporal Sharing – Evaluate potential for time-based sharing that can take advantage of satellite tracks and antenna look angles. Is there a potential for, or value in, to dynamically reducing exclusion zones as look angle increases or when satellites are not in view?
- 7) Coordination zones versus exclusion zones to protect satellite receiver stations or a combination of the two.
- 8) TBD - level of testing - Consider the Possibility and necessity of a live test between LTE handset and earth station to evaluate and verify the magnitude and impact of interference

## **Appendix 6**

### **GOES and POES Overview and Characteristics**



# **NOAA Satellite Operations Overview**

**Presented to:**  
**Commerce Spectrum Management Advisory Committee (CSMAC)**  
**Working Group 1**

**Presented by: Mark Mulholland**  
**Senior Advisor/Chief Systems Engineer**  
**Office of Systems Development**  
**NOAA Satellite and Information Service (NESDIS)**



# Topics



- **Short Course: NOAA 1.01**
- **NOAA Satellite Enterprise**
- **Fast-Track Report: Recommendation & Impacts**
- **Polar Operations Affected by Sharing**
- **Interference Effects on Selected Polar Products**
- **Non-real Time Terrestrial Distribution**



# NOAA 1.01

# NOAA 1.01

## NOAA'S MISSION:

Science, Service, and Stewardship

*To understand and predict changes in climate, weather, oceans, and coasts,*

*To share that knowledge and information with others, and*

*To conserve and manage coastal and marine ecosystems and resources.*

**SCIENCE**



**SERVICE**



**STEWARDSHIP**





# NOAA Supports Businesses, Communities, and the Future

NOAA enables short-term economic opportunities *and* long-term economic prosperity

Support transportation



Protect life & property and create business opportunities

Safeguard communication and electric infrastructure

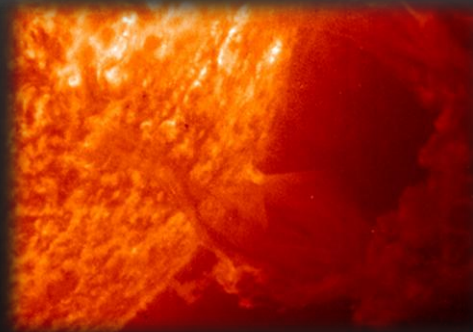

Facilitate sustainable agriculture, fisheries, and aquaculture



Assist communities & provide recreational opportunities



Inform renewable energy business decisions

# National Primary Mission Essential Functions

Collect and provide the Nation with intelligence data, imagery, and other essential information for predictive environmental and atmospheric modeling systems and space-based distress alert systems by operating NOAA-controlled satellites, communications equipment, and associated systems

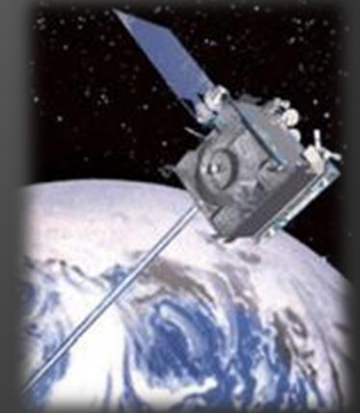

Provide the Nation with environmental forecasts, warnings, data, and expertise critical to public safety, disaster preparedness, all-hazards response and recovery, the national transportation system, safe navigation, and the protection of the Nation's critical infrastructure and natural resources





# Federal Government Customers

- Agriculture (USDA)
- Commerce (NOAA: National Weather Service, NESDIS, Office of Oceanic & Atmospheric Research, National Ocean Service, Office of Marine & Aviation Operations)
- Defense (USAF-AF Weather Agency, Navy, Army)
- Homeland Security (US Coast Guard, FEMA)
- Interior (Bureau of Land Management, US Geological Survey)
- Transportation (FAA, FHWA)
- Environmental Protection Agency
- National Aeronautics & Space Administration
- Nuclear Regulatory Commission
- State Department



# Non-Federal Customers



- State, local, and tribal governments
- State, local, tribal, and private emergency managers
- Media, entertainment & communications industry
- Energy, transportation, agriculture, medical, environmental sectors
- Industries directly supporting federal users
- Rail, airline, and shipping industries
- Thousands of universities
- Hemispheric and global users, many of whom who also contribute data from their own systems
- Any individual with a satellite dish and computer



# NOAA SATELLITE ENTERPRISE



# Operational Satellite Programs



- Geostationary satellites (GOES) – 4 on orbit
- Polar-orbiting satellites (POES + Suomi NPP) – 6 on orbit
- Defense Meteorological Satellite Program (DMSP) – 6 on orbit
- Jason-2 Altimetry satellite – international cooperative program
- Primary operational uses:
  - Numerical weather forecasting models used to improve forecast accuracy
  - Current weather forecasts – terrestrial and space weather
  - Generation of specialized warnings and alerts – terrestrial and space





# Additional Operations

- **Satellites**
  - **Advanced Composition Explorer (ACE) – Solar Wind**
  - **Constellation Observing System for Meteorology, Ionosphere, and Climate (COSMIC) – 6 spacecraft**
- **Rebroadcast services**
  - **Emergency Manager’s Weather Information Network**
  - **Data Collection Platform data**
  - **Imagery & other products**
- **Satellite Search & Rescue**



# Primary Ground Stations

## Fairbanks Command, Data, and Acquisition Station



- Telemetry, command & mission data
  - GOES
  - POES
  - Jason-2
  - ACE
- LRIT, DCS Local Readout Ground Station, EMWIN

## NOAA Satellite Operations Facility Suitland, Maryland



## Svalbard Satellite Station Kongsberg Satellite Services



- Telemetry, command & mission data: Suomi NPP
- Service-level agreement for POES, MetOp, others

## Wallops Command, Data, and Acquisition Station



- Telemetry, command & mission data
  - POES
  - DMSP
  - Jason-2
  - COSMIC
  - Landsat
- GOES-West backup
- Suomi NPP backup



# Different Orbits For Complimentary Missions

**GOES: Constant staring; POES: high resolution**

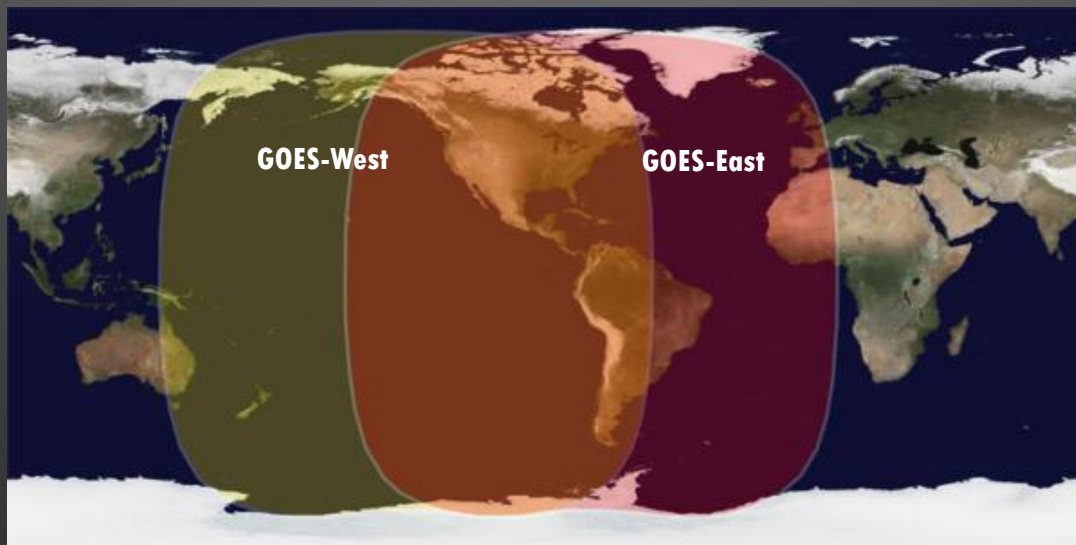

Coverage by one POES in one rotation

Coverage by one POES over 6 hours

Coverage by two POES over 6 hours





# Satellite Data Flow

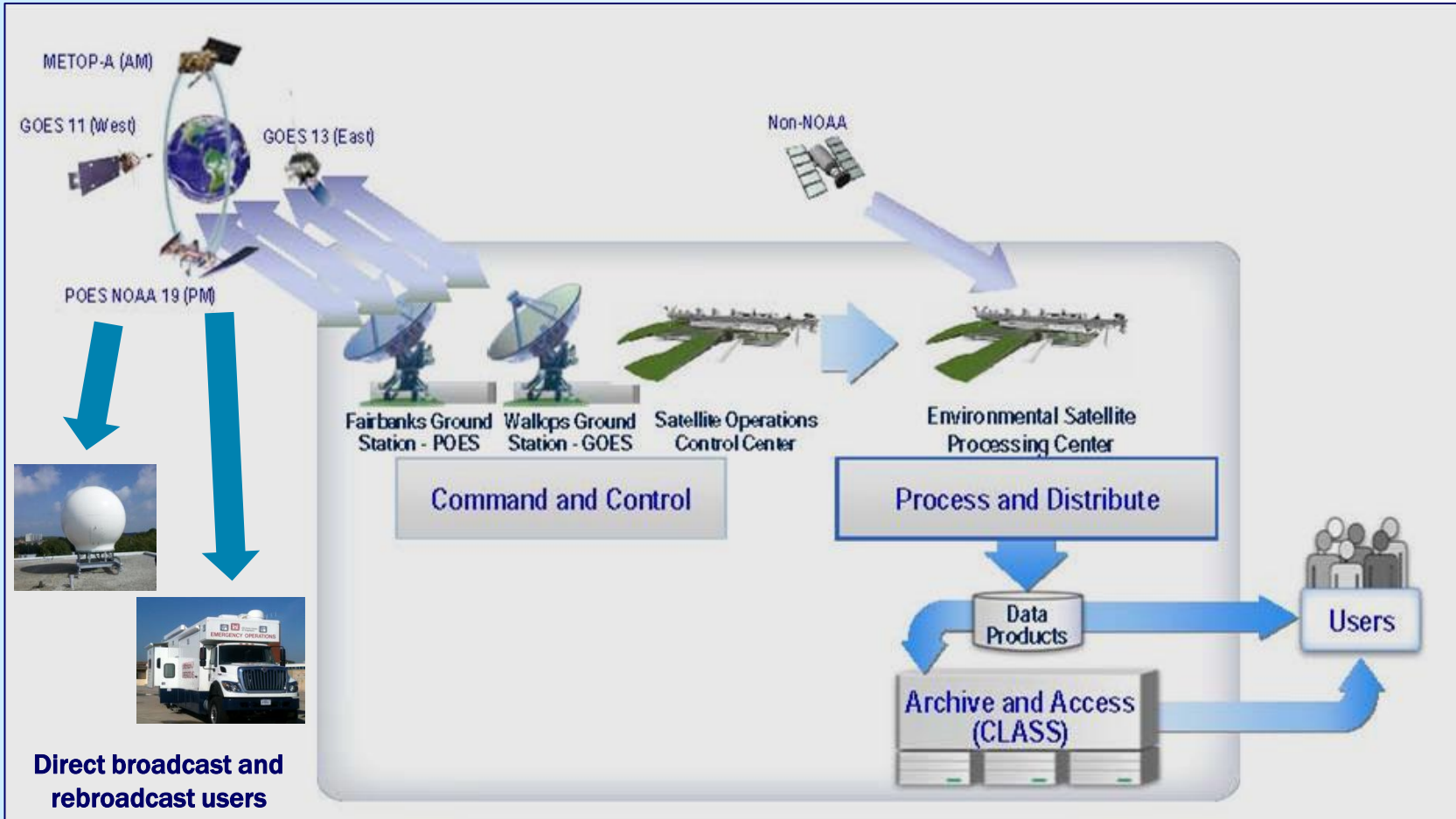



# **FAST-TRACK REPORT RECOMMENDATION & IMPACTS**



# Polar L-Band Identified For Sharing

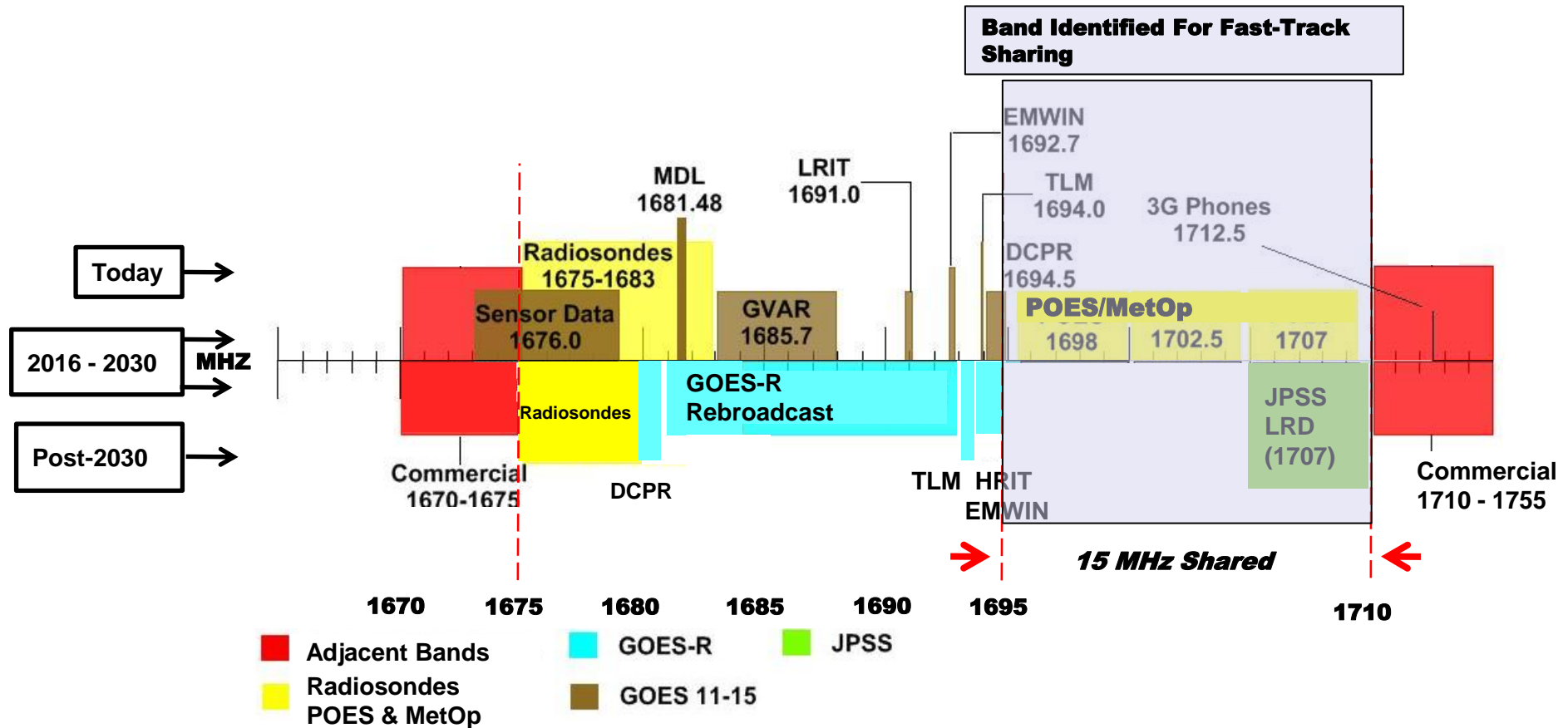

## STATUS

- Launches of first GOES-R Series and first JPSS occur in ~2016
- Legacy and new radiosonde and satellite systems will operate simultaneously through end of missions of last POES, MetOp, and GOES-N Series
- ~2030 is projected date when last legacy spacecraft will cease operations



# Exclusion Zones Around Critical Federal Government Sites

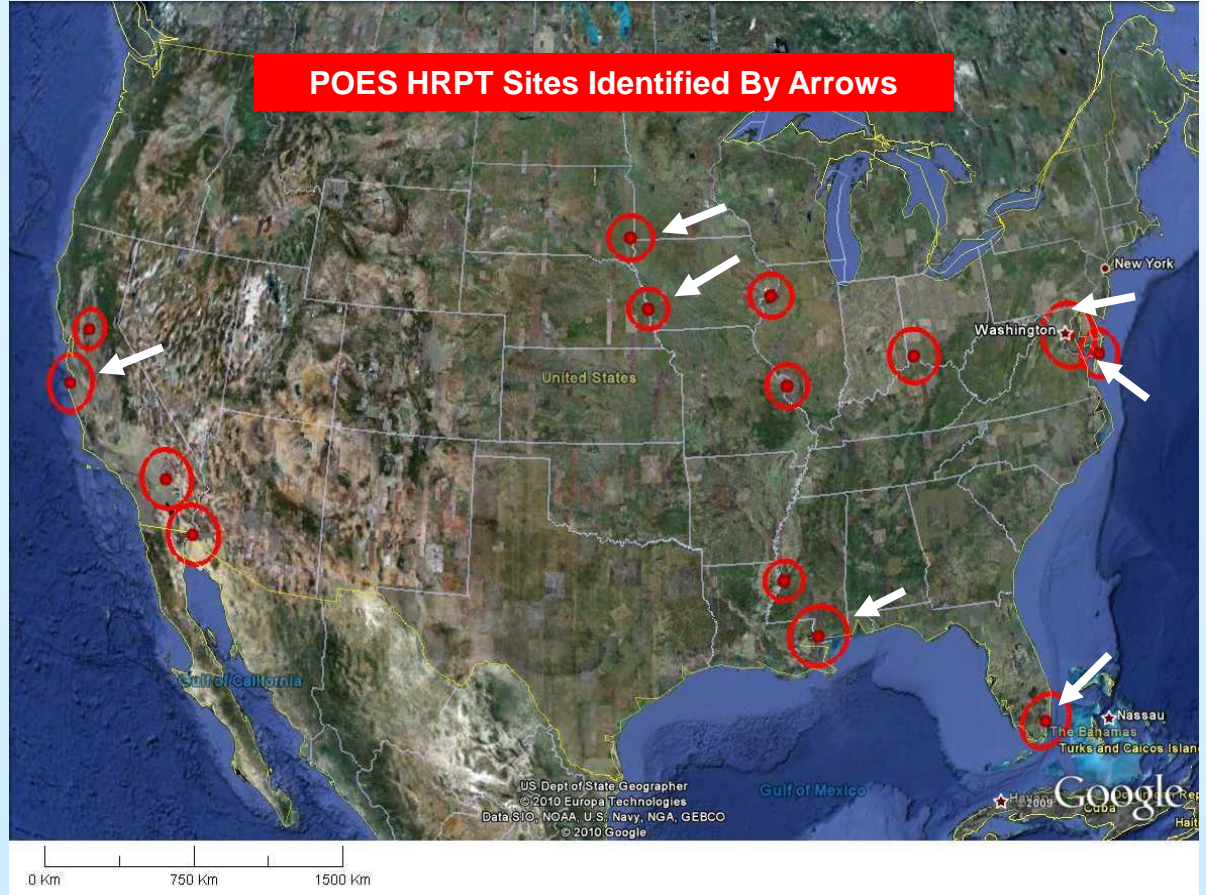
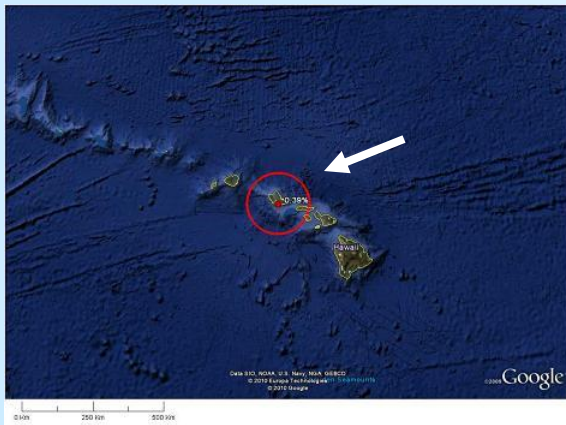
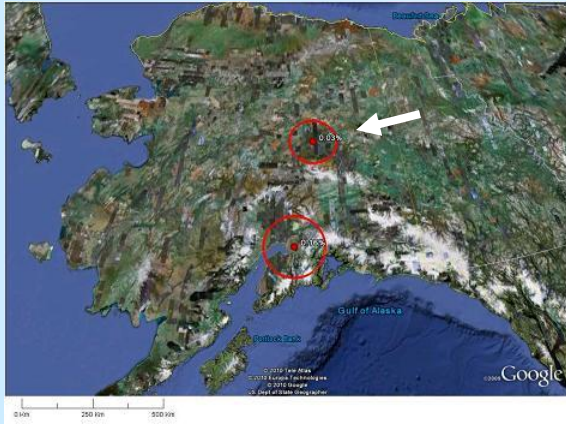



# Interference Threat For Unprotected Users



- Terrestrial Emission may interfere with
  - Downlink Data
  - Tracking of Satellite
- Depending on
  - Relative Position
  - Relative Signal Strength
  - Operating Frequency
  - Bandwidth
- Possible causes: In-band, adjacent band, ducting



Polar

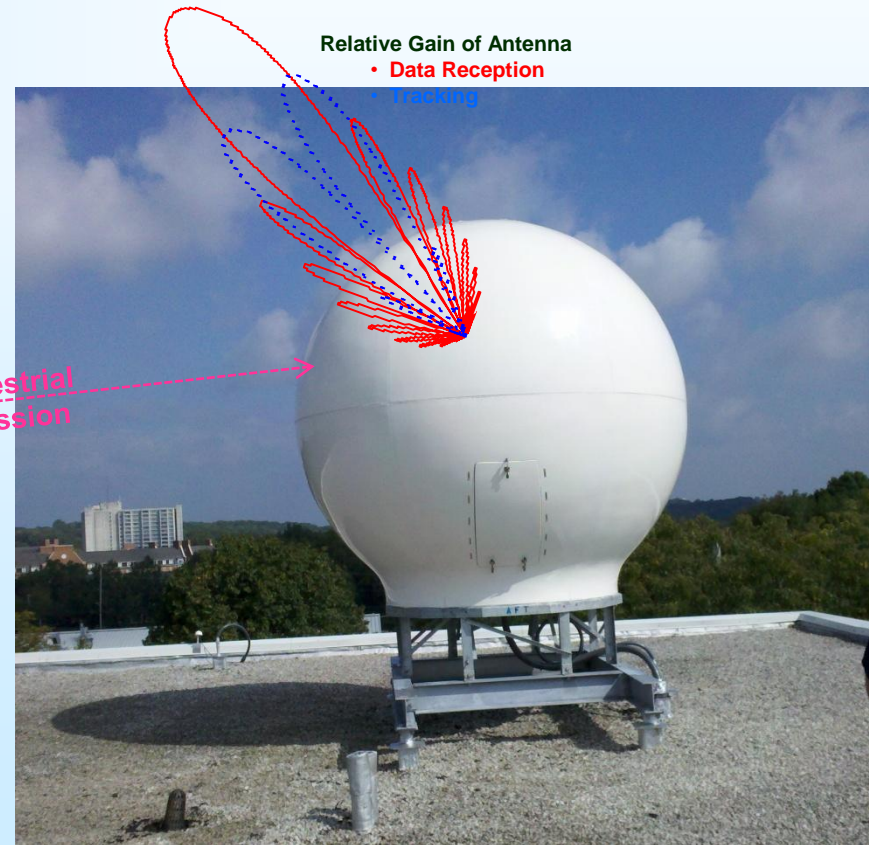

Motion of Tracking Antenna can align with Terrestrial Emitter



Motion of Antenna

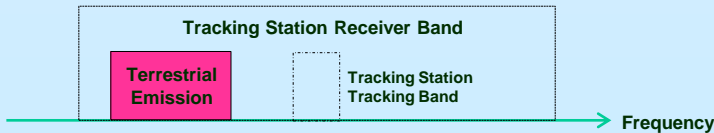

Unprotected User - University of Delaware



# **POLAR OPERATIONS IN 1695- 1710 MHZ**



# How Polar Satellites Work

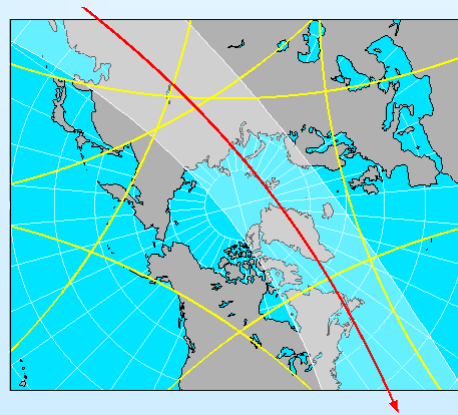
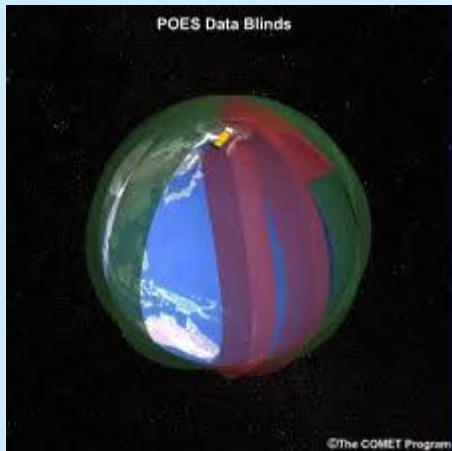
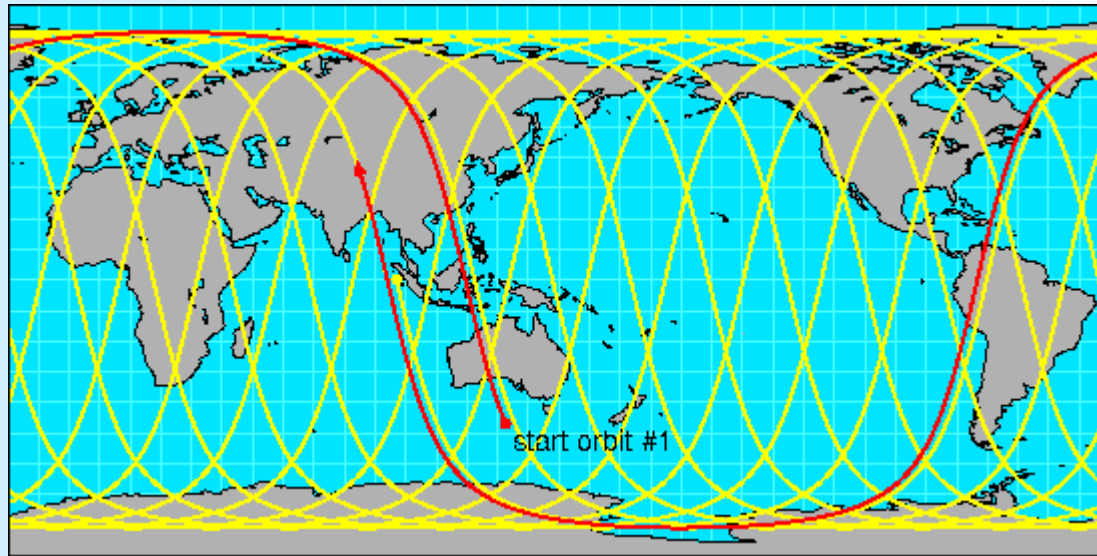





# POES Direct Broadcast Services

## High Resolution Picture Transmission (HRPT):

- Provides worldwide direct readout of full-resolution spacecraft parameters and instrument data to ground stations within the footprint of the NOAA polar orbiters
- Transmissions contain data from all instruments aboard the NOAA polar satellites

## Automatic Picture Transmission (APT):

- 4-km (2.5-mi)-resolution IR and visible imagery from the POES imager
- Transmitted within the footprint of the NOAA polar orbiter – users see what the satellite sees when the satellite sees it

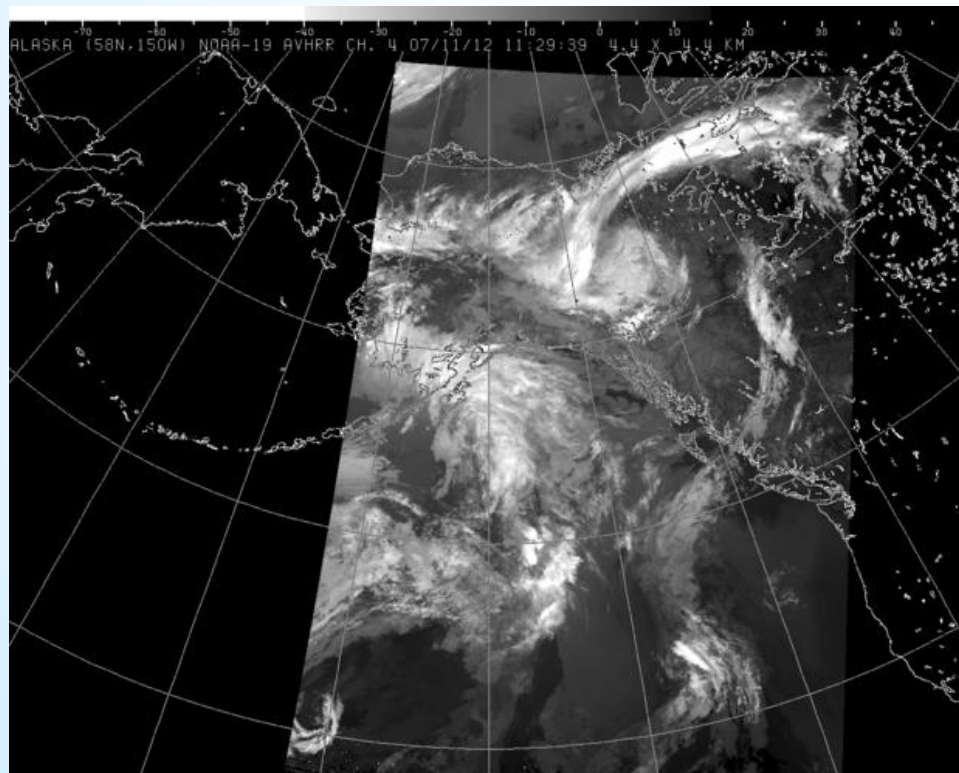



# HRPT: More Than Just Imagery...



- **POES Spacecraft**
  - High Resolution Infrared Sounder (HIRS)
  - Advanced Microwave Sounding-A1 (AMSU-A1)
  - Advanced Microwave Sounding-A2 (AMSU-A2)
  - Microwave Humidity Sounder (MHS)
  - Solar Backscatter Ultraviolet Radiometer (SBUV)
  - Space Environmental Monitor (SEM)
  - Argos Advance Data Collection Unit (ADCS)
  - Advanced Very High Resolution Radiometer (AVHRR)
  - TIROS Information Processor (spacecraft health & status data and telemetry)
- **MetOp-A Spacecraft**
  - High Resolution Infrared Sounder (HIRS),
  - Advanced Microwave Sounding-A1 (AMSU-A1)
  - Advanced Microwave Sounding-A2 (AMSU-A2)
  - Global Ozone Monitoring Experiment (GOME)
  - Global Navigation Satellite System Receiver for Atmospheric Sounding (GRAS)
  - Infrared Atmospheric Sounding Interferometer (IASI)
  - Microwave Humidity Sounder (MHS)
  - Space Environmental Monitor (SEM)
  - Argos Advance Data Collection Unit (ADCS)
  - Advanced Very High Resolution Radiometer (AVHRR)

# Satellite Products and Services

- Atmospheric temperature/moisture profiles
- Vegetation greenness indices
- Volcanic Ash
- Hurricane intensity and position
- Significant Precipitation
- Fire and Smoke
- Oil Spills
- Sea surface temperature
- Sea ice extent
- Satellite derived winds
  - Speed/direction/height
- Search and Rescue
- Data Collection Services

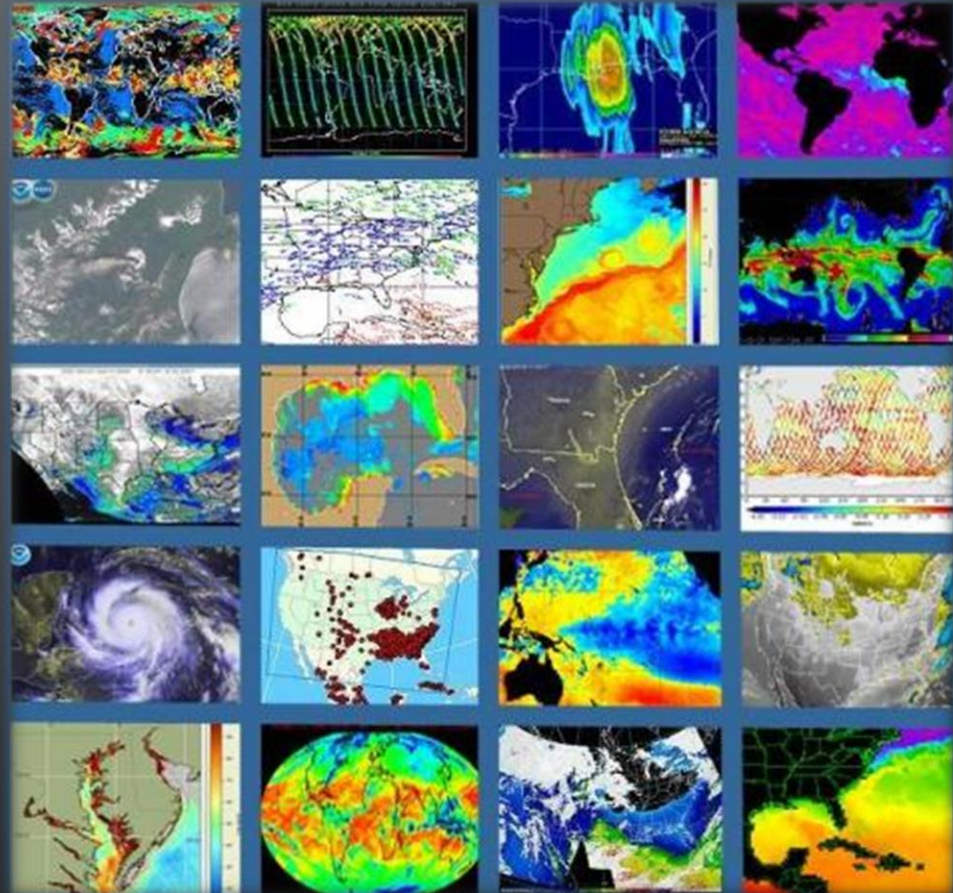



# Polar Direct Broadcast Users

- **Over 160 known U.S. users receive NOAA real time polar data**
  - State, local, & tribal governments; universities; fishing and aviation sectors; media
  - Common locations: coastal areas; regions prone to severe weather, fires or floods
- **Major international users include: Germany, Italy, Argentina, Canada, Mexico**
- **Examples of critical real-time uses include:**
  - Civil aviation flight safety: Detection and warnings of microbursts around airports
  - First-responders: Imagery and products received directly by first-responders
  - Fishing industry: Ocean temperature products used to track fish movements and to monitor compliance with fishing regulations
  - Coastal storm monitoring: Hurricane intensity, surge and flooding detection
  - High-latitude weather forecasting: Heavy reliance on polar data in northern regions
  - Firefighting: Polar imagery used to detect “hot spots” and monitor fire progression
  - Media: Weather Channel repackages polar data into a format relevant to the public
  - Major universities performing world-class environmental research



# **INTERFERENCE EFFECTS ON SELECTED POLAR PRODUCTS**



# Example of Polar-orbiting Satellite Imagery Interference - Miami Direct Broadcast

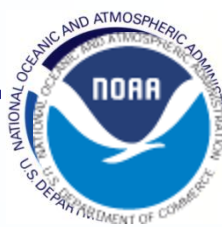

NOAA-18: Interference Free

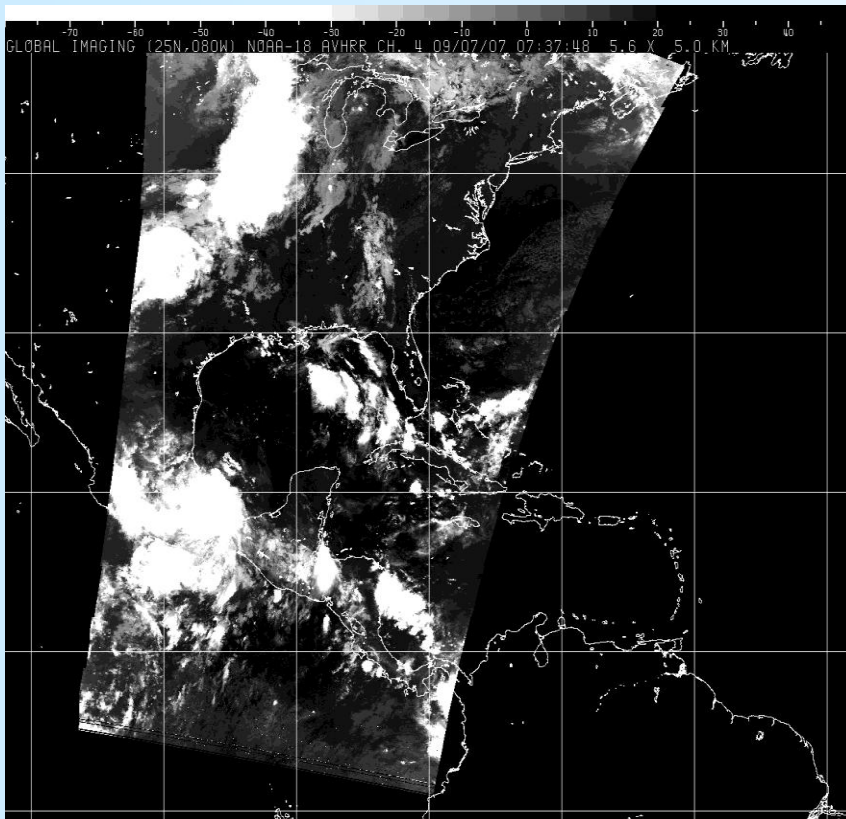

NOAA-16: 2 hrs later - Interference

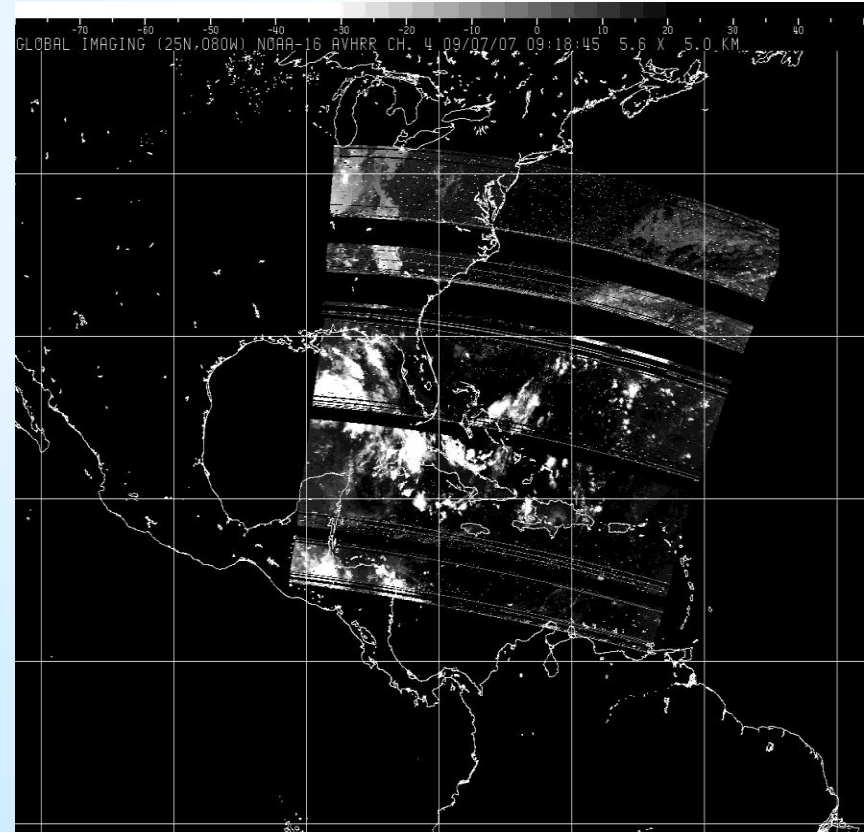

# Regression of Hurricane Track Accuracy

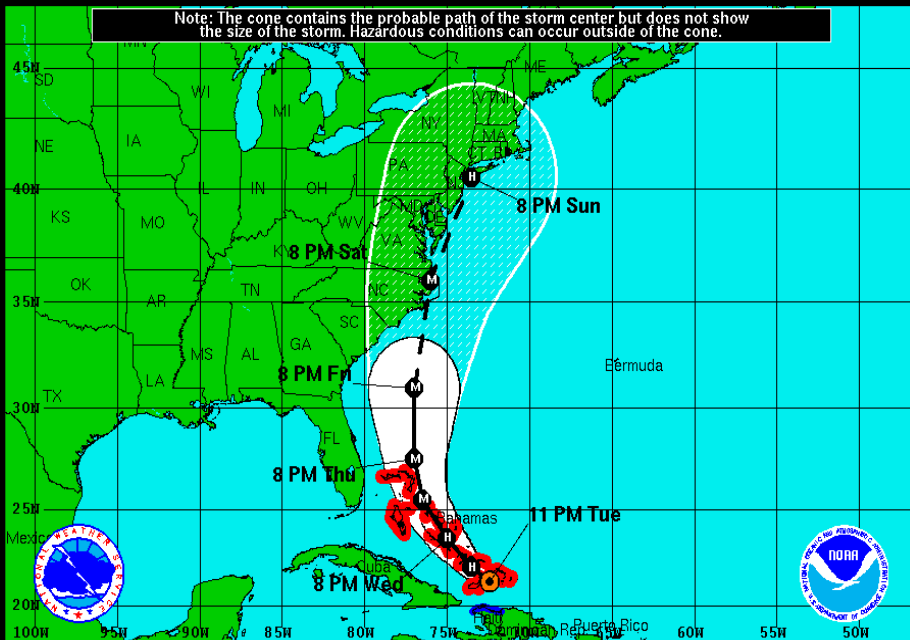

**Hurricane Irene**  
 Tuesday August 23, 2011  
 11 PM EDT Advisory 15  
 NWS National Hurricane Center

**Current Information:** ●  
 Center Location 21.3 N 72.4 W  
 Max Sustained Wind 90 mph  
 Movement WNW at 9 mph

**Forecast Positions:**  
 ● Tropical Cyclone ○ Post-Tropical  
 Sustained Winds: D < 39 mph  
 S 39-73 mph H 74-110 mph M > 110mph

**Potential Track Area:**  
 Day 1-3 Day 4-5

**Watches:**  
 Hurricane Trop.Storm

**Warnings:**  
 Hurricane Trop.Storm

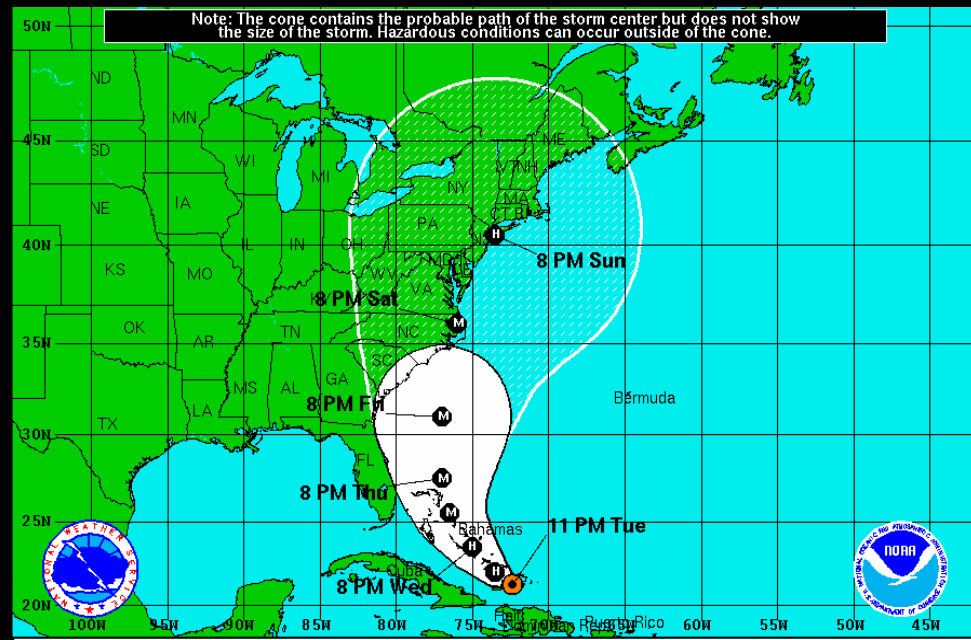

**Hurricane Irene**  
 Tuesday August 23, 2011  
 11 PM EDT Advisory 15  
 NWS National Hurricane Center

**Current Information:** ●  
 Center Location 21.3 N 72.4 W  
 Max Sustained Wind 90 mph  
 Movement WNW at 9 mph

**Forecast Positions:**  
 ● Tropical Cyclone ○ Post-Tropical  
 Sustained Winds: D < 39 mph  
 S 39-73 mph H 74-110 mph M > 110mph

**Potential Track Area:**  
 Day 1-3 Day 4-5

**Watches:**  
 Hurricane Trop.Storm

**Warnings:**  
 Hurricane Trop.Storm

## 2011 Irene Forecast

## Irene "2001" Forecast

- Continual interference could cause regression of capabilities
- FEMA likely to have ordered needless evacuation of FL, GA coastal residents
- Cost to state & local governments: \$600K - \$1M per mile (GOES Economic Study [2006])



# Sea Surface Temperature (SST) Degradation

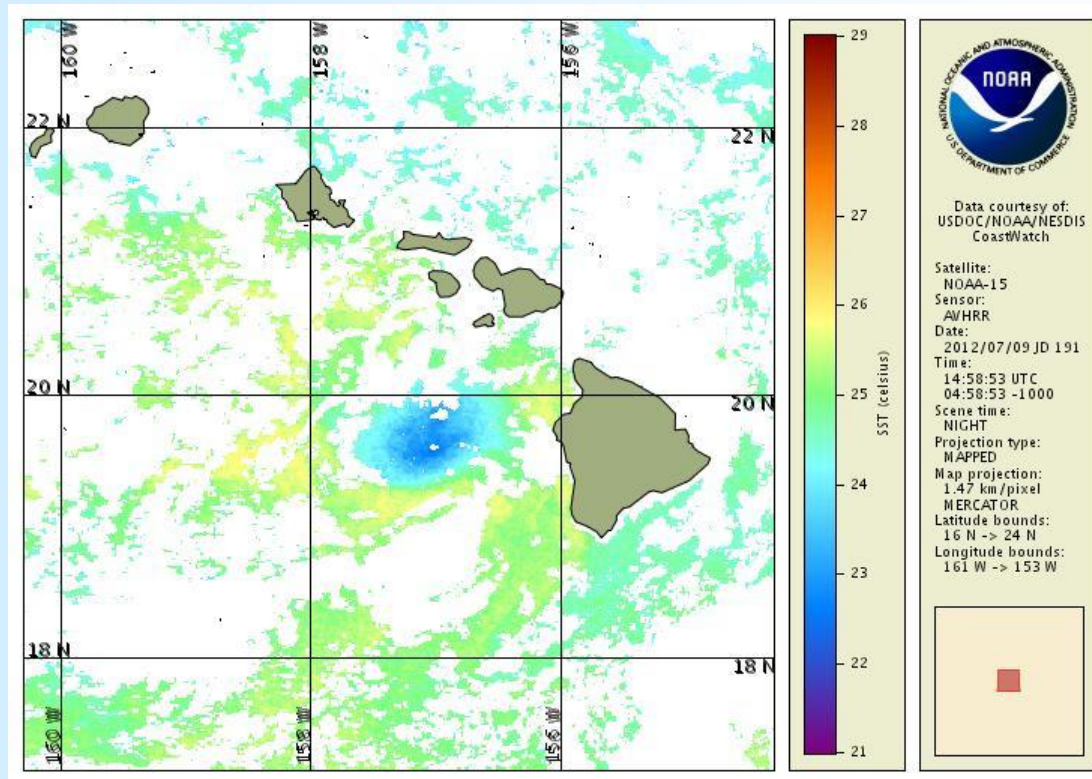

- Received at EWA Beach, HI – data from ~8 passes per day
- Degraded product results in:
  - Fish school location inaccuracy – (fishing industry and enforcement)
  - Reduction in weather forecasting accuracy – SST is key storm predictor
  - Reduction in El Nino accuracy – Less accurate seasonal weather forecasts



# Less Timely and Accurate Post-Storm Environmental Damage Assessments

Satellite imagery of total suspended matter following Tropical Storm Lee. Used by Maryland Department of Natural Resources.

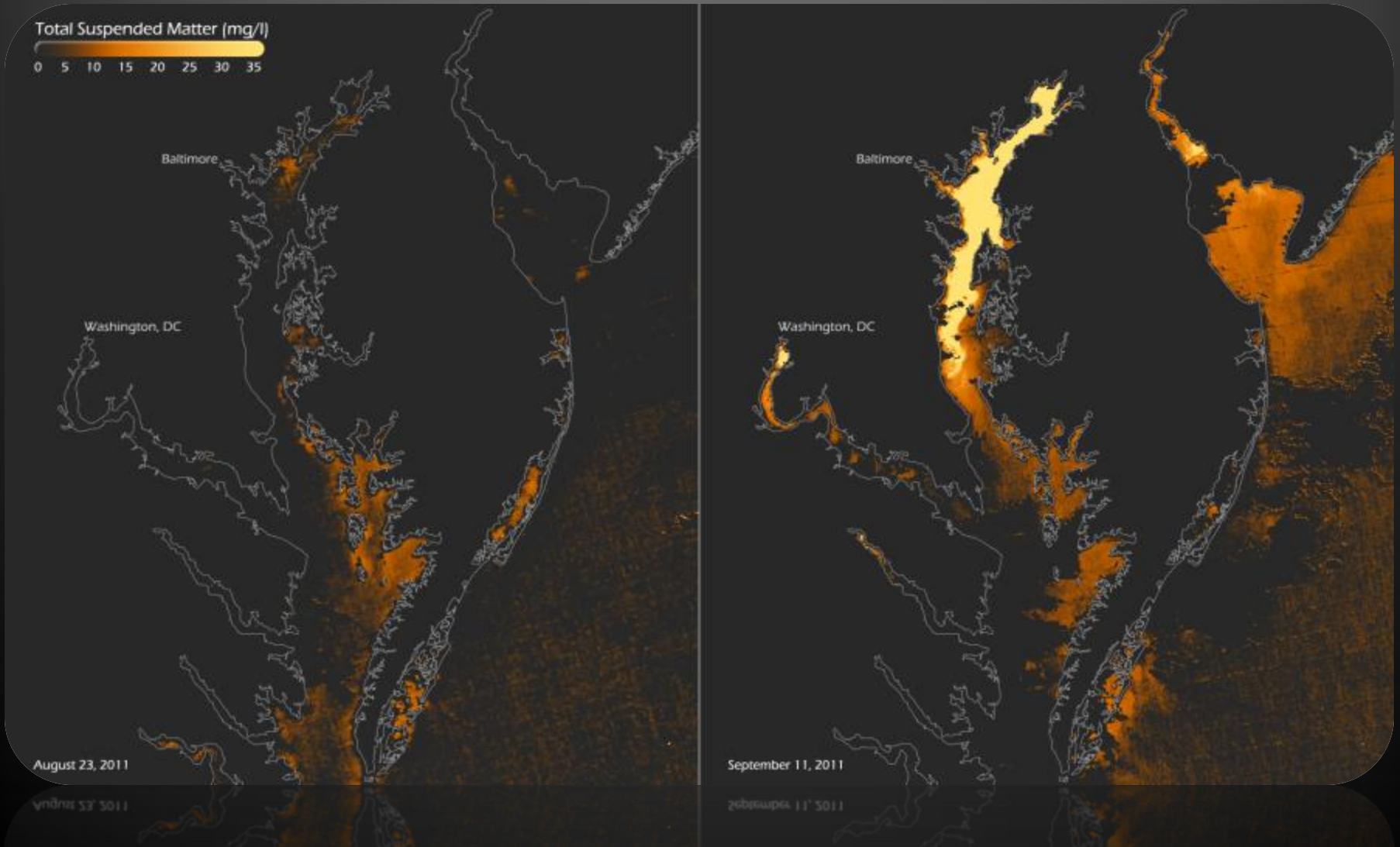



# Degradation of Wildfire Monitoring

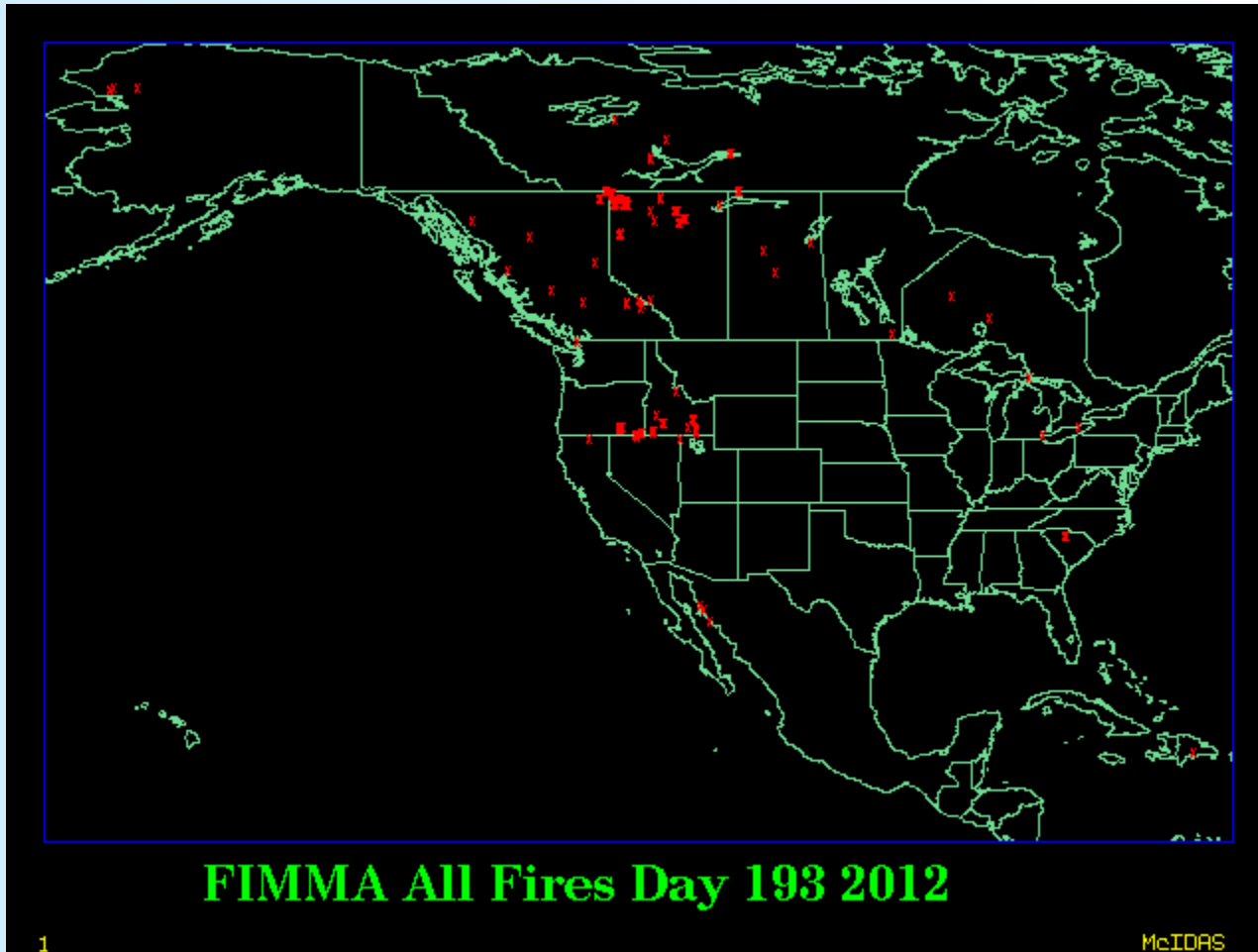

Fire Identification, Mapping and Monitoring Algorithm (FIMMA)  
Polar satellite fire detection product



# Mission Impacts

- Interference results in permanent loss of imagery and critical real-time products
- Unacceptable availability and reliability of polar satellite data
- Unprotected users (outside exclusion zones with 4G wireless present) face significantly increased risk of interference and loss of real-time products
- Potential loss of environmental research at numerous universities, ending of years of research and secondary products they've built on NOAA imagery
- Loss of critical imagery required for severe weather forecasting
- Polar direct broadcast cannot be replaced by terrestrial distribution methods
  - No on-board capability to store high-resolution imagery for later downlink
  - No relay satellites or crosslinks



# Questions?

## Appendix 7

# ANALYSIS METHODOLOGY USED TO COMPUTE PROTECTION DISTANCES FOR FEDERAL METEOROLOGICAL-SATELLITE RECEIVERS

Analysis method and results provided by Edward Drocella, NTIA

## INTRODUCTION

This document describes the analysis methodology used for computing the interference protection distances necessary to protect the federal meteorological-satellite receivers operating in and adjacent to the 1695-1710 MHz band identified for reallocation from federal to non-federal use from harmful interference from commercial UE transmitters.

## ANALYSIS METHODOLOGY DESCRIPTION

An electromagnetic compatibility analysis was performed between UE transmitters and federal meteorological-satellite receivers operating in and adjacent to the 1695-1710 MHz band. The analyses supported the determination of the interference protection distances and/or other technical or operational characteristics necessary to preclude potential interference between federal meteorological-satellite receivers and UE transmitters.

### Calculation of UE Aggregate Interference Level

The interference power levels at the federal meteorological-satellite receiver are calculated using Equation 1 for each UE transmitter considered in the analysis.

$$I = EIRP + G_R - L_R - L_P - FDR \quad (1)$$

where:

I	Received interference power at the input of the meteorological-satellite receiver (dBm);
EIRP	UE transmitter EIRP (dBm);
G <sub>R</sub>	Antenna gain of the meteorological-satellite receiver in the direction of the UE transmitter (dBi); <sup>1</sup>
L <sub>Add</sub>	Additional losses (dB);
L <sub>P</sub>	Propagation loss (dB); and
FDR	Frequency dependent rejection (dB).

Using Equation 1, the values of interference power level are calculated for each mobile/portable station being considered in the analysis. These individual interference power

---

<sup>1</sup> There are no additional losses included for polarization mismatch losses.

## Appendix 7

levels from each UE transmitter are then used in the calculation of the aggregate interference to the federal meteorological-satellite receivers using Equation 2.<sup>2</sup>

$$I_{AGG} = 10 \log \left[ \sum_{j=1}^N I_j \right] + 30 \quad (2)$$

where:

- $I_{AGG}$  Aggregate interference to the federal meteorological-satellite receiver from UE transmitters (dBm);
- $N$  Number of UE transmitters; and
- $I$  Interference power level at the input of the federal meteorological-satellite receiver from an individual UE transmitter (Watts).

The difference between the received aggregate interference power level computed using Equation 2 and the receiver interference protection criteria represents the available margin. When the available margin is positive, compatible operation is possible. The distance at which the available margin is zero represents the minimum distance separation that is necessary to protect the meteorological-satellite receiver.

### UE EIRP

The EIRP of each UE used to compute the aggregate interference level is randomly selected in accordance with the CDF curves for each independent Monte-Carlo analysis trial. There is a UE EIRP CDF curve for each of the urban/suburban and rural regions. The EIRP levels used in the analysis range from a maximum value of 20 dBm to a minimum value of -30 dBm.

### Meteorological-Satellite Receive Earth Station Antenna Model

The antenna model for the meteorological-satellite receive Earth stations is based on Recommendation ITU-R F.1245-1.<sup>3</sup> The model is used to represent the azimuth and elevation antenna gain.

In cases where the ratio between the antenna diameter and the wavelength is greater than 100 ( $D/\lambda > 100$ ), the following equations will be used:

$$G(\varphi) = G_{max} - 2.5 \times 10^{-3} \left( \frac{D}{\lambda} \varphi \right)^2 \quad \text{for } 0^\circ < \varphi < \varphi_m \quad (3)$$

---

<sup>2</sup> The interference power calculated in Equation 1 must be converted from dBm to Watts before calculating the aggregate interference seen by the Federal system receiver using Equation 2.

<sup>3</sup> Recommendation ITU-R F.1245-1, *Mathematical Model of Average or Related Radiation Patterns for Line-of-Sight Point-to-Point Radio Relay System Antenna for Use in Certain Coordination Studies and Interference Assessment in the Frequency Range from 1 GHz to About 70 GHz* (2000).

## Appendix 7

$$G(\varphi) = G_1 \quad \text{for } \varphi_m \leq \varphi < \max(\varphi_m, \varphi_r) \quad (4)$$

$$G(\varphi) = 29 - 25 \log \varphi \quad \text{for } \max(\varphi_m, \varphi_r) \leq \varphi < 48^\circ \quad (5)$$

$$G(\varphi) = -13 \quad \text{for } 48^\circ \leq \varphi \leq 180^\circ \quad (6)$$

where:

$G_{max}$	Maximum antenna gain (dBi)
$G(\varphi)$	Gain relative to an isotropic antenna (dBi)
$\varphi$	Off-axis angle (degrees)
$D$	Antenna diameter (m)
$\lambda$	Wavelength (m)
$G_1$	Gain of the first side lobe = $2 + 15 \log(D/\lambda)$

$$\varphi_m = \frac{20\lambda}{D} \sqrt{G_{max} - G_1} \quad \text{degrees} \quad (7)$$

$$\varphi_r = 12.02(D/\lambda)^{-0.6} \quad \text{degrees} \quad (8)$$

In cases where the ratio between the antenna diameter and the wavelength is less than or equal to 100 ( $D/\lambda \leq 100$ ), the following equation will be used:

$$G(\varphi) = G_{max} - 2.5 \times 10^{-3} \left( \frac{D}{\lambda} \varphi \right)^2 \quad \text{for } 0^\circ < \varphi < \varphi_m \quad (9)$$

$$G(\varphi) = 39 - 5 \log(D/\lambda) - 25 \log \varphi \quad \text{for } \varphi_m \leq \varphi < 48^\circ \quad (10)$$

$$G(\varphi) = -3 - 5 \log(D/\lambda) \quad \text{for } 48^\circ \leq \varphi \leq 180^\circ \quad (11)$$

$D/\lambda$  is estimated using the following expression:

$$20 \log \frac{D}{\lambda} \approx G_{max} - 7.7$$

where:

$G_{max}$ :	Maximum antenna gain (dBi)
-------------	----------------------------

The antenna pattern for a 43 dBi mainbeam antenna gain is shown in Figure 1.

## Appendix 7

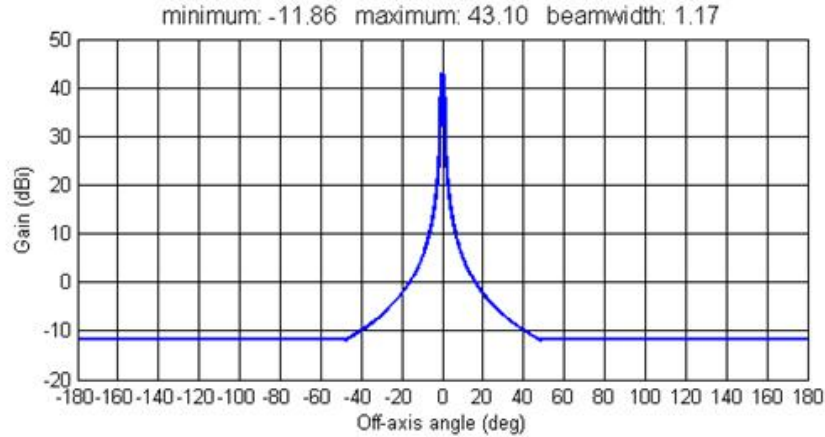

**Figure 1. Azimuth and Elevation Antenna Pattern**

The minimum elevation angle for each meteorological-satellite receive antenna is used to determine the antenna gain in the direction of the UE.

Signals from the polar orbiting meteorological-satellites can be received at any azimuth angle. An analysis was performed using minimum propagation loss to determine the worst-case azimuth angle used in the analysis. The worst case azimuth angle for each of the polar orbiting meteorological-satellite receivers is provided in Table 1.

**Table 1. Worst-Case Azimuth Angles for Polar Orbiting Meteorological-Satellites**

Meteorological-Satellite Receiver Location	Worst Case Azimuth Angle (Degrees) <sup>a</sup>
Wallops Island, Virginia	0
Fairbanks, Alaska	90
Suitland, Maryland	270
Miami, Florida	210
Kaena Point/Hickam Air Force Base/Pearl Harbor, Hawaii	0
Sioux Falls, South Dakota	210
Elmendorf Air Force Base, Alaska	0
Anderson Air Force Base, Guam	210
Monterey, California	30
Stennis Space Center, Mississippi	30
Twenty-Nine-Palms, California	120
Yuma, Arizona	30
Note a: Azimuth angles are relative to true north	



## Appendix 7

Signals from the geostationary meteorological-satellites are received at fixed azimuth angles. The azimuth angle for each geostationary orbiting meteorological-satellite receivers are provided in Table 2.

**Table 2. Azimuth Angles for Geostationary Orbiting Meteorological-Satellites**

Meteorological-Satellite Receiver Location	Latitude	Longitude	GOES Longitude	Minimum Elevation Angle (Degrees)	Azimuth Angle (Degrees) <sup>a</sup>
Cincinnati, Ohio	390608N	843036W	75W 135W 137W	43.9	165.1 242.5 244.2
Rock Island, Illinois	413104N	903346W	75W 135W 137W	24.4	157.2 235.9 237.8
St Louis, Missouri	383526N	901225W	75W 135W 137W	42.6	156.5 237.9 239.6
Vicksburg, Mississippi	322123N	905129W	75W 135W 137W	48.6	152 241.1 242.8
Omaha, Nebraska	411532N	955520W	75W 135W 137W	28	149.9 230.9 232.9
Sacramento, California	383459N	1212939W	75W 135W 137W	43.2	120.6 201.1 203.9

Note a: Azimuth angles computed using Microcomputer Spectrum Analysis Models SATAZ program and are relative to true north.<sup>4</sup>

### Additional Losses

An additional factor is included for additional losses associated with meteorological-satellite receiver insertion loss, cable loss, polarization mismatch loss, etc. A nominal value of 1 dB will be included in the analysis.

### Propagation Model

The propagation model used in the Fast Track Evaluation was the Irregular Terrain Model (ITM) in the Area Prediction Mode. In the ITM Area Prediction Mode, the “area” is described by the terrain roughness factor  $\Delta h$ , which is defined as the interdecile (0.1 to 0.9) value computed from the range of all terrain elevations for the area. Suggested values of  $\Delta h$  are

<sup>4</sup> The Microcomputer Spectrum Analysis Models software package can be downloaded from <http://ntiacsd.ntia.doc.gov/msam>.

## Appendix 7

available for different types of terrain. Using the  $\Delta h$  value and the antenna heights for the system, the algorithm predicts the signal attenuation as a function of distance.

The appropriate propagation model to be used in the aggregate interference analysis to compute the protection distances was discussed within the CSMAC Working Group. The industry representatives presented several propagation models.<sup>5</sup> In general it was found that most of these existing propagation models are used for predicting signal strength and propagation path loss for relatively short range paths (i.e., distances less than 20 km) in built-up urban/suburban areas where there are numerous man-made building structures. Propagation models based on this methodology tend to underestimate interference for small percentages of time. Frequently these propagation models are used for system design and do not characterize the time variability of the propagation path. Since these models particularly overestimate propagation loss at small time percentages, they are not appropriate for interference calculations. Various methods of modeling clutter losses were also discussed, but the working group could not reach a consensus approach to implement. Several of the federal agencies stated that anomalous propagation effects should also be taken into account.<sup>6</sup> Ducts are an atmospheric phenomenon that can occur under certain conditions, however there is no empirical evidence that supports assuming all of the signals from a large number of widely dispersed UE operating at low antenna heights will be enhanced simultaneously at very low time percentages resulting in correlation of ducted signals to cause an aggregate interference effect at the meteorological-satellite receivers.<sup>7</sup>

Differences in the industry proposed propagation models and ITM Area Mode and the application of clutter losses can have a dramatic impact on the propagation loss with results varying by as much as 40 dB. Based on the discussions within the working group it was determined that there is no single propagation model that can be used in the analysis to cover all of the possible interference paths between the randomly distributed UEs and the meteorological-satellite receivers.

The CSMAC Working Group did agree that using a propagation model that takes into account the actual terrain around the meteorological-satellite receiver would provide a more accurate as compared to the terrain roughness factor used in the Fast Track Evaluation. For the aggregate compatibility analysis associated with the meteorological-satellite receivers, the ITM in the Point-to-Point Mode will be used. Since the Point-to-Point Mode uses actual terrain data it

---

<sup>5</sup> The models proposed by the industry representatives included the Okumura-Hata and COST-231 models.

<sup>6</sup> Anomalous propagation includes different forms of electromagnetic wave propagation that are not encountered in a standard atmosphere due to a non standard distribution of temperature and humidity with height in the atmosphere. While technically the term includes propagation with larger losses than in standard atmosphere, in practical applications it is most often meant to refer to cases when signal propagates beyond normal radio horizon. An example of an anomalous propagation effect is atmospheric ducting.

<sup>7</sup> For atmospheric ducting to occur both the UE and meteorological-satellite receivers would have to be within the heights of the ground based ducts. Large values of terrain irregularity tend to work against ducting.

## Appendix 7

should provide a better estimate of the propagation loss. The statistical and environmental parameters used with the actual terrain profiles in calculating propagation loss are shown in Table 3.

**Table 3. ITM Point-to-Point Mode Parameters**

<b>Parameter</b>	<b>Value</b>
Surface Refractivity	301 N-units
Conductivity of Ground	0.005 S/M
Dielectric Constant of Ground	15
Polarization	Vertical
Reliability	50 percent
Confidence	50 percent
Frequency	1702.5 MHz
Transmitter Antenna Height	1.5 meters
Receiver Antenna Height	Variable
Radio Climate	Continental Temperate
Terrain Database	United States Geological Survey (USGS) - 3 Second <sup>8</sup> GLOBE – 30 Second <sup>9</sup>

There were no additional losses associated with clutter or building attenuation included in the analysis.

### **Frequency Dependent Rejection**

Frequency Dependent Rejection (FDR) accounts for the fact that not all of the undesired transmitter energy at the receiver input will be available at the detector. FDR is a calculation of the amount of undesired transmitter energy that is rejected by a victim receiver. This FDR attenuation is composed of two parts: on-tune rejection (OTR) and off-frequency rejection (OFR). The OTR is the rejection provided by a receiver selectivity characteristic to a co-frequency transmitter as a result of an emission spectrum exceeding the receiver bandwidth, in dB. The OFR is the additional rejection, caused by specified detuning of the receiver with respect to the transmitter, in dB. The FDR values used in this analysis were computed using an automated program.

In the case of an undesired transmitter operating co-frequency to a victim receiver, the FDR is represented by the OTR using the following simplified form shown in Equation 12.

---

<sup>8</sup> The USGS terrain data downloadable from the following links:

[http://ntiacsd.ntia.doc.gov/msam/TOPO/USGS\\_CDED/T3Sec01.zip](http://ntiacsd.ntia.doc.gov/msam/TOPO/USGS_CDED/T3Sec01.zip)

[http://ntiacsd.ntia.doc.gov/msam/TOPO/USGS\\_CDED/T3Sec02.zip](http://ntiacsd.ntia.doc.gov/msam/TOPO/USGS_CDED/T3Sec02.zip)

[http://ntiacsd.ntia.doc.gov/msam/TOPO/USGS\\_CDED/T3Sec03.zip](http://ntiacsd.ntia.doc.gov/msam/TOPO/USGS_CDED/T3Sec03.zip)

[http://ntiacsd.ntia.doc.gov/msam/TOPO/USGS\\_CDED/T3Sec04.zip](http://ntiacsd.ntia.doc.gov/msam/TOPO/USGS_CDED/T3Sec04.zip)

<sup>9</sup> The GLOBE 30 second terrain data can be downloaded from the <http://www.ngdc.noaa.gov/mgg/topo/gltiles.html> website. The GLOBE data was used in areas where there is no USGS terrain data.

## Appendix 7

$$OTR = \max \left[ 0, 10 \log \left( \frac{B_{tx}}{B_{rx}} \right) \right] \quad (12)$$

where:

- $B_{tx}$  : Emission bandwidth of the transmitter
- $B_{rx}$  : Intermediate Frequency (IF) bandwidth of the receiver

The transmitter emission spectrum and receiver selectivity curves used to compute the FDR are defined in terms of a relative attenuation level specified in decibel as a function of frequency offset from center frequency in megahertz.

The POES meteorological-satellite receivers can operate on three center frequencies: 1698 MHz, 1702.5 MHz, and 1707 MHz. The receiver 3 dB IF bandwidth is approximately between 1 MHz and 1.33 MHz. As discussed in Section 3, the UE each have a 1.6667 MHz emission bandwidth and also operate across the entire band. Since the three receiver center frequencies and UEs can at any instant operate across the entire 1695-1710 MHz band, OFR was not computed. Using Equation 12, a value of 1 dB for OTR was included in the analysis.

The GOES meteorological-satellite receivers operate on center frequency of 1694.5 MHz with a 3 dB IF bandwidth of 1.5 MHz. The 3 dB IF bandwidth extends above 1695 MHz. As discussed in Appendix 3, the UE OOB emissions are modeled as a constant level below 1695 MHz referenced to a measurement bandwidth of 1 MHz based on the 3GPP standard. Thus OOB emission level falls within the passband of the meteorological-satellite receiver that cannot be filtered. Since the meteorological-satellite receiver bandwidth is wider than the 1 MHz specified for the OOB emissions the OTR included in the analysis is 0 dB. To address the overlap that occurs from the meteorological-satellite receivers operating at 1694.5 MHz, the EIRP of one UE in each sector is selected in the same fashion as the in-band EIRP is selected representing a UE at the 1695 MHz band edge. The OFR for this component of interference included in the analysis is 0 dB. The EIRP values for the remaining UEs that are further in frequency from the 1695 MHz band edge are reduced based on the Appendix 3 SEM for each channel bandwidth.

### Meteorological-Satellite Receiver Interference Protection Criteria

The interference protection criteria ( $I_T$ ) for the meteorological-satellite receivers are determined using Equation 13.<sup>10</sup>

$$I_T = I/N + N \quad (13)$$

where:

---

<sup>10</sup> The receiver interference protection criteria is referred to as a long-term criteria because their derivation assumes that the interfering signal levels are present most of the time.

## Appendix 7

- I/N      Maximum permissible interference-to-noise ratio at the receiver IF output (detector input) necessary to maintain acceptable performance criteria (dB)
- N        Receiver inherent noise level at the receiver IF output referred to the receiver input (dBm)

For a known receiver IF bandwidth and receiver noise figure (NF) or system noise temperature, the receiver inherent noise level is given by:

$$N = -114 [dBm] + 10 \log(B_{IF}[MHz]) + NF \quad (14)$$

$$N = kT_s B_{IF} = -198.6 [dBm/K/Hz] + 10 \log(T_s [K]) + 10 \log(B_{IF} [Hz]) \quad (15)$$

where:

- $B_{IF}$       Receiver IF bandwidth (see equations for units)
- NF        Receiver noise figure (dB)
- $k$         Boltzmann's constant,  $1.38 \times 10^{-23}$  (Watts/K/Hz)
- $T_s$       System noise temperature (Kelvin)

The analysis will use an I/N of -10 dB, corresponding to a 0.4 dB increase in the receiver noise to establish the interference protection criteria for the meteorological-satellite receivers. Using the receiver IF bandwidth, noise figure, and noise temperature for each meteorological-satellite receiver, the interference protection criteria for the meteorological-satellite receivers are shown in Table 4.

**Table 4. Meteorological-Satellite Receiver Interference Protection Criteria**

Meteorological-Satellite Receiver	Interference Protection Criteria (dBm)
Wallops Island, Virginia	-120.6
Fairbanks, Alaska	-120.6
Suitland, Maryland	-120.9
Miami, Florida	-124.1
Kaena Point/Hickam Air Force Base/Pearl Harbor, Hawaii	-120.9
Sioux Falls, South Dakota	-121.6
Cincinnati, Ohio	-122.5
Rock Island, Illinois	-122.5
St. Louis, Missouri	-122.5
Vicksburg, Mississippi	-122.5
Omaha, Nebraska	-122.5
Sacramento, California	-122.5
Elmendorf Air Force Base, Alaska	-120.9
Anderson Air Force Base, Guam	-120.9
Monterey, California	-120.9

## Appendix 7

<b>Meteorological-Satellite Receiver</b>	<b>Interference Protection Criteria (dBm)</b>
Stennis Space Center, Mississippi	-120.9
Twenty-Nine-Palms, California	-120.9
Yuma, Arizona	-120.9

### **DESCRIPTION OF PROTECTION DISTANCE MODEL**

The following paragraphs describe how the analysis methodology is used to compute the protection distance for the meteorological-satellite receivers based on the controlling the aggregate interference by eliminating base stations and their associated UEs.

Figure 2 shows an overhead view of the base station distribution around meteorological-satellite receiver in Sioux Falls (the receiver is at the center of the distribution). Base stations are shown with two different densities. From the center out to a distance of 30 km is the urban/suburban region. From a distance of 30 km out to a distance of 100 km is the rural region. In the urban/suburban region base stations are deployed using a inter-site distance (ISD) is 1.732 km.<sup>11</sup> In the rural region base stations are deployed using a ISD of 7 km. There are 1088 base stations in the urban region and 670 base stations in the rural region for a total of 1758 base stations.

---

<sup>11</sup> ISD is the distance between a base station and its nearest neighbor.

## Appendix 7

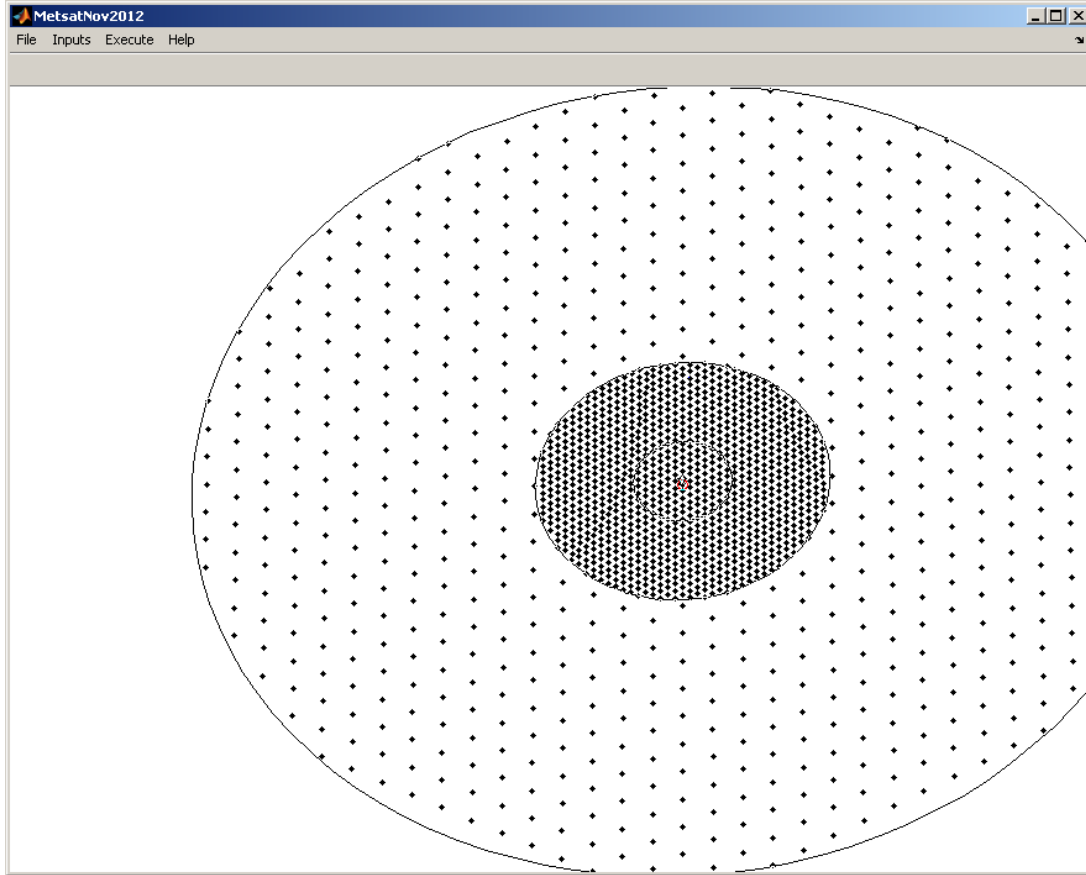

**Figure 2. Example of Base Station Distribution**

Figure 3 shows that each base station has a coverage circle associated with it. There are 18 UE associated with each base station which are randomly scattered anywhere from 10 m from the base station out to the edge of the coverage circle. The UE are shown as blue dots. The coverage circle radii were chosen to form a honeycomb pattern. The coverage circles in the urban region have a radius of 0.92998 km. The rural base stations have coverage circles with a radius of 3.7586 km. Geographic boundaries limit where base stations are deployed. Base stations are not distributed in the ocean or in other geographic areas (e.g., Everglades).

## Appendix 7

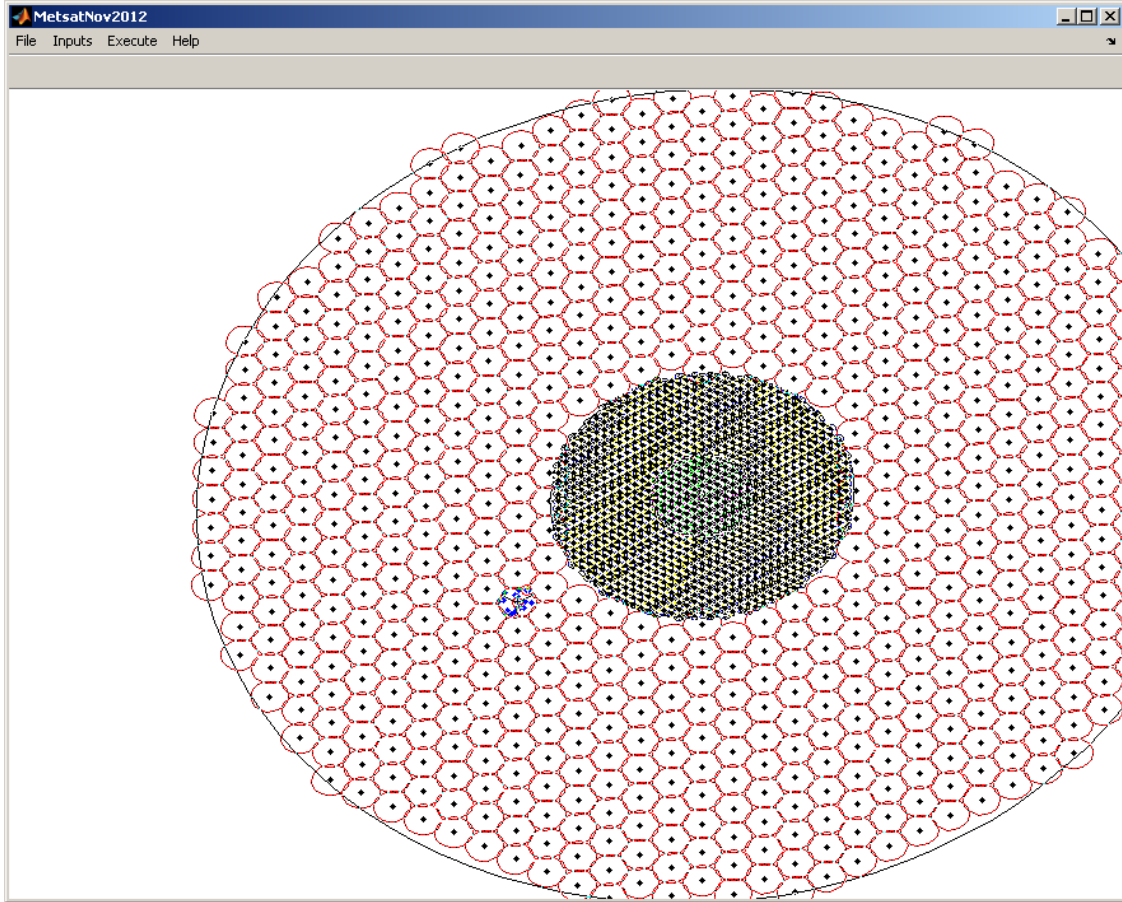
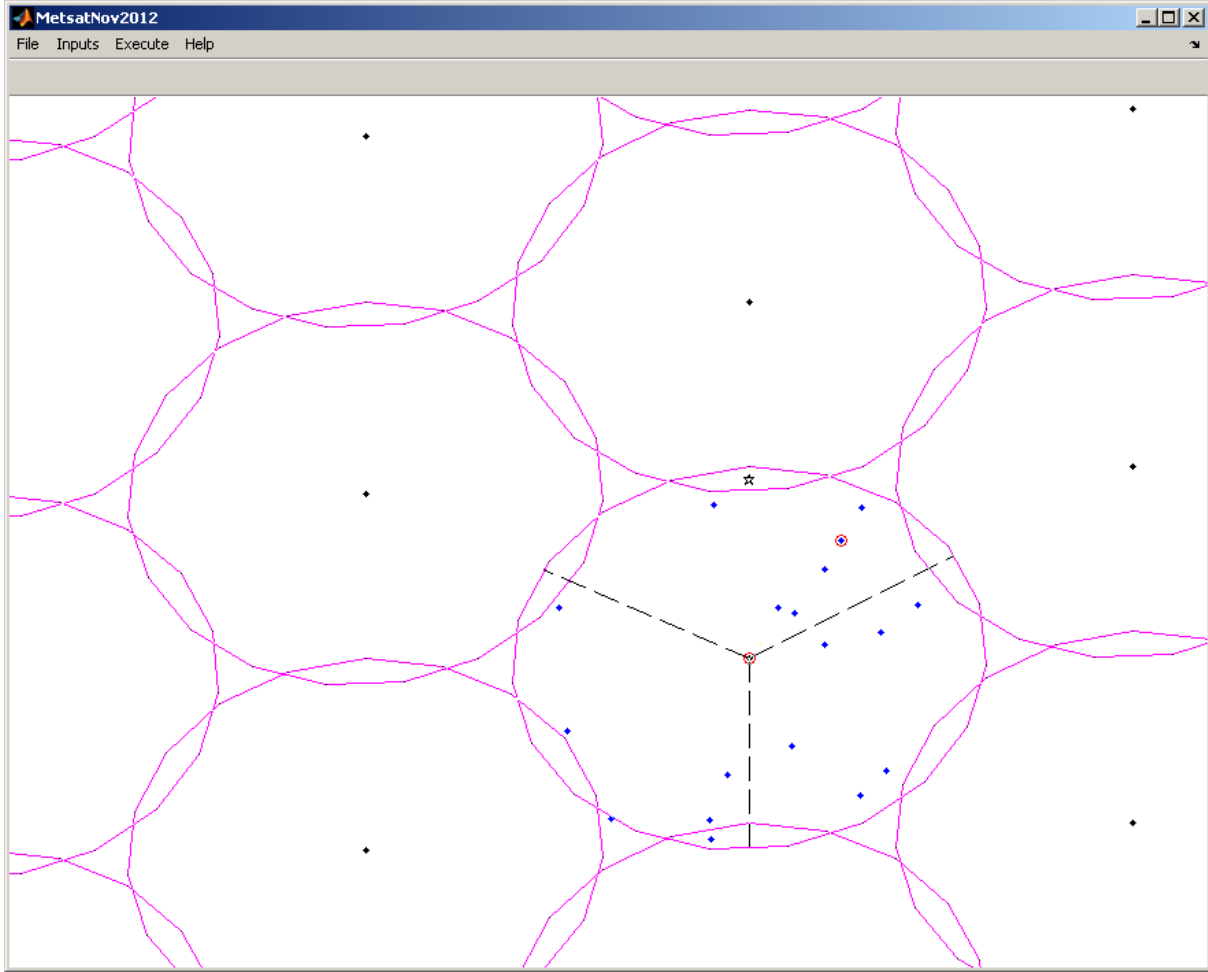

**Figure 3. Example of Base Station Deployment Coverage Areas**

In Figure 4 at the center of the base station distribution the star represents the receiver. The honeycomb pattern of base stations is offset so that base stations appear 0.866 km directly above and below the meteorological-satellite receiver. The UEs associated with each base station are shown in Figure 4. Each base station coverage circle is divided into 3 sectors. For a 10 MHz channel bandwidth there are 6 UEs randomly distributed within each base station sector for a total of 18 UEs per base station.



## Appendix 7



**Figure 4. Example of Base Station Sectors and Associated UE**

The relation of base stations to each other is completely independent of the meteorological-satellite receiver and is determined only by the minimum distance between any two base stations determined by the ISD. The base stations are distributed in a honeycomb (worst-case) configuration centered on the meteorological-satellite receiver. The results of the model are used to regulate is the distance any base station can get to the receiver. To mitigate interference to the meteorological-satellite receiver base stations and associated UE are eliminated as needed to protect the receiver. The protection distance algorithm eliminates base stations within a vector of distance with respect to the meteorological-satellite receiver. The aggregate interference is calculated for base stations outside of each element of the protection distance vector. Figure 5 shows a protection distance vector in 1 km increments from 1 to 99 km (the black concentric circles). The outermost circle in this figure is the 100 km extent of the distribution.

## Appendix 7

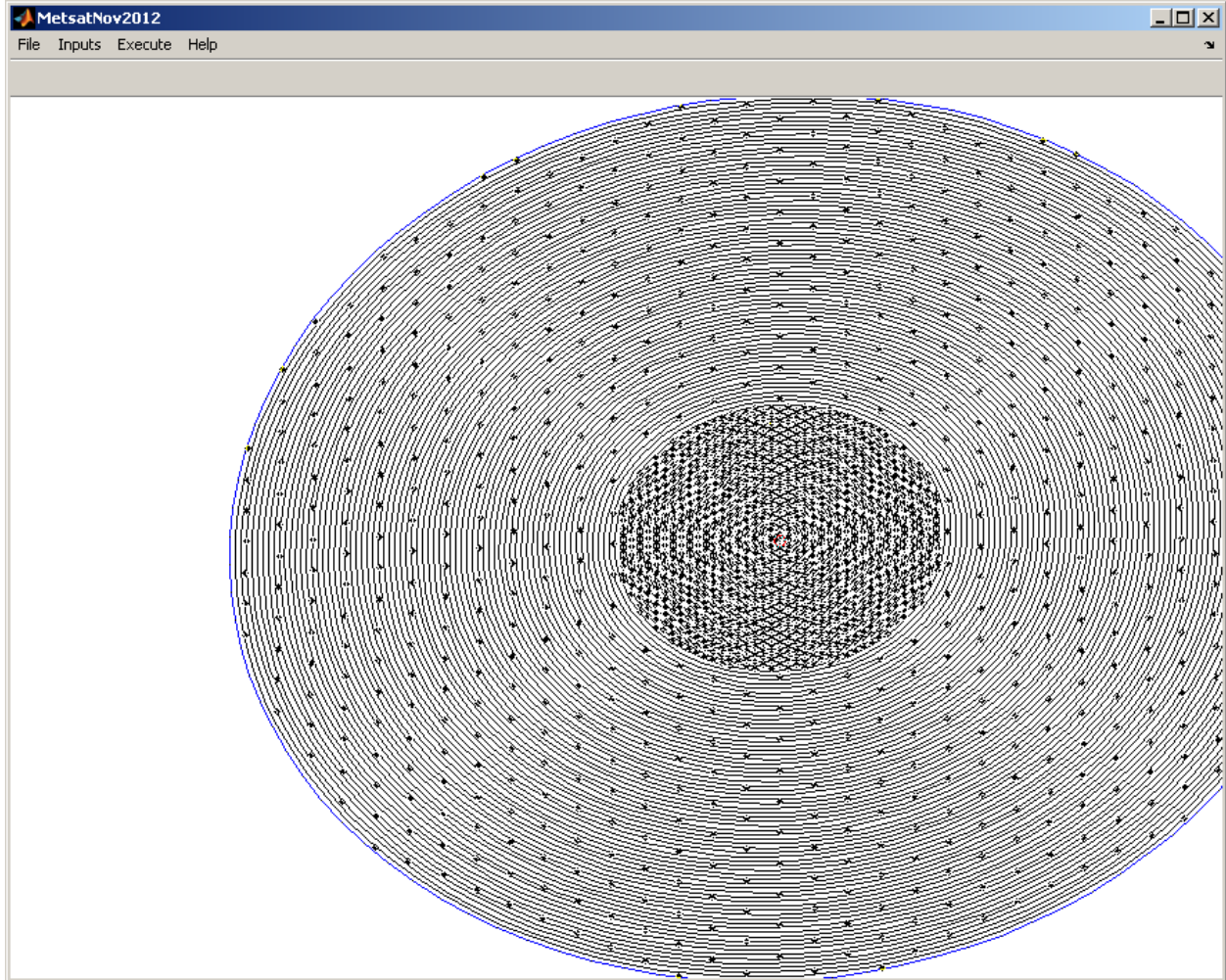

**Figure 5. Example of Protection Distance Vectors (1 km Increments)**

Figure 6 is an expanded view. The meteorological-satellite has a directional antenna pointed at an azimuth angle of 210 degrees and elevation angle of 27.7 degrees. The two closest base stations (to the receiver) are within the smallest exclusion radius (1 km), therefore they would not be included in any of the aggregate interference calculations.

## Appendix 7

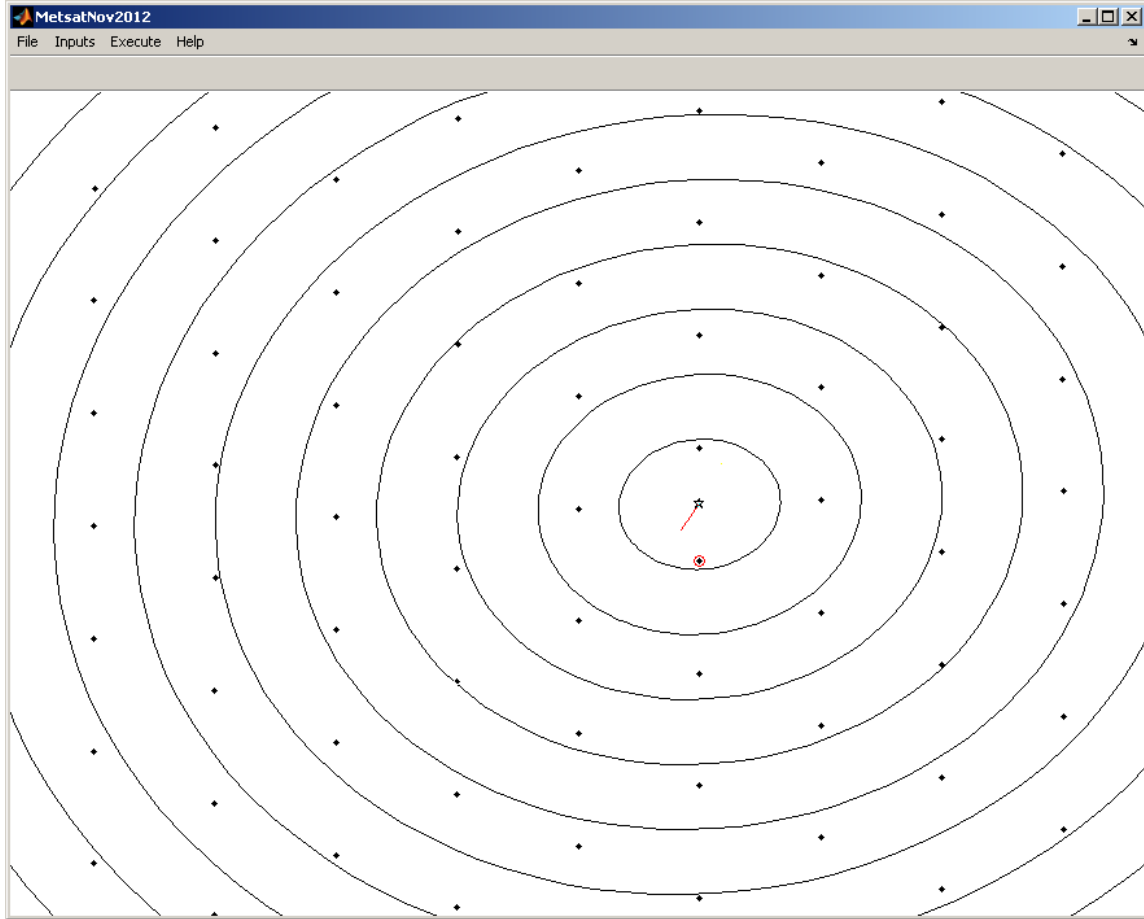

**Figure 6. Example of Expanded View of Base Station Deployment**

For the 1 km protection distance radius base stations within 1 km would be eliminated from the aggregate interference calculation. Figure 7 shows the UEs associated with a base station which would be included in the 1 km protection distance radius aggregate calculation. The UE is shown as a blue dot surrounded by a small red circle. This UE is only 0.70407 km from the meteorological-satellite receiver, well within the 1 km protection distance radius, yet its associated base station is outside (1.5 km away), therefore this base station and associated UEs would be included in the aggregate interference calculation for the 1 km protection distance radius.

## Appendix 7

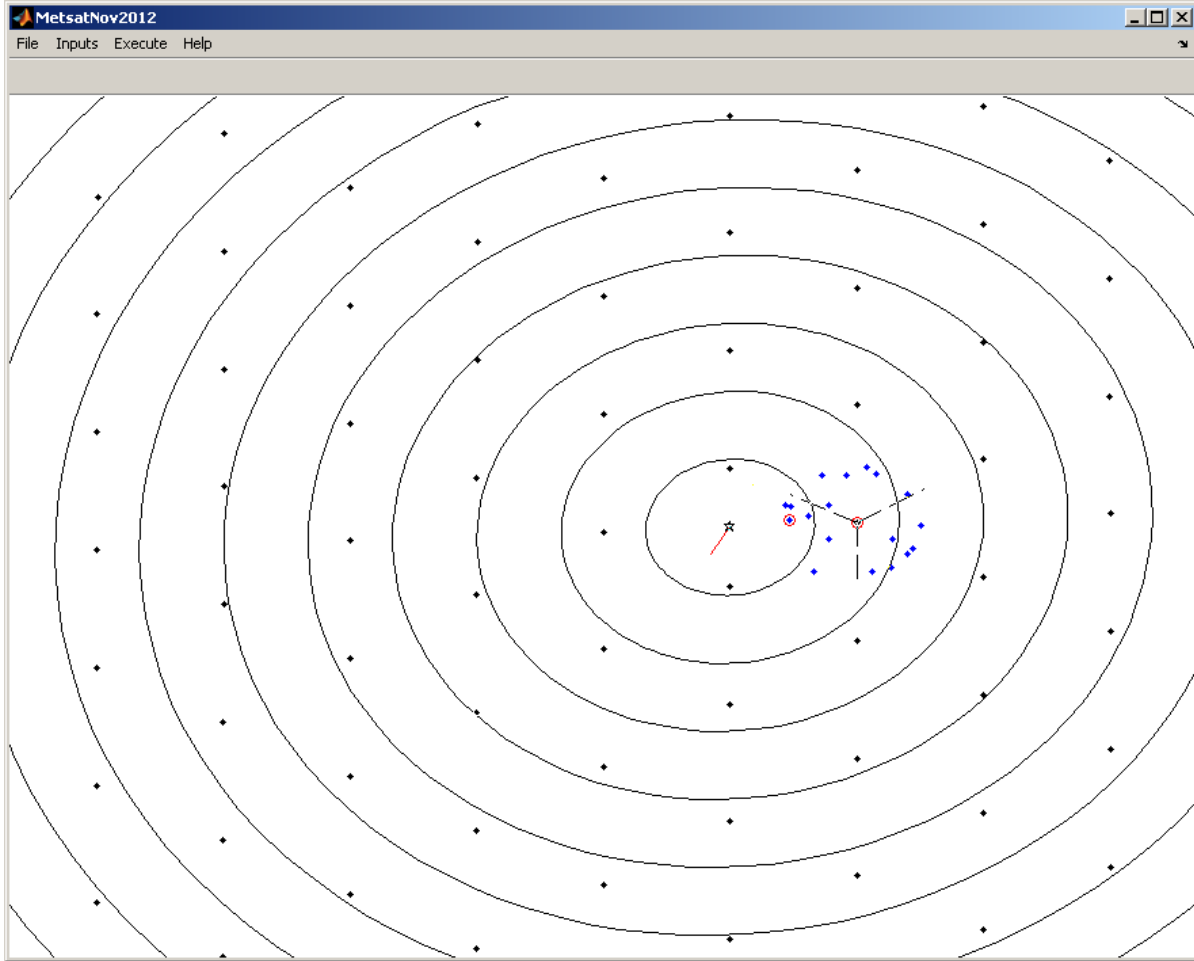

**Figure 7. Example of UW Associated With a Single Base Station**

As shown in Figure 7, for the 2 km protection distance radius base stations would be excluded from the aggregate interference calculation. This process is repeated 97 more times performing aggregate interference calculations with increasingly larger protection distance radii. The results of the model are shown in Table 5. As expected this table shows monotonically decreasing aggregate interference power levels with increasing protection distance radius. There could be a case where the aggregate interference is the same for successive protection distance radii. For example the protection distances at 32 km and 33 km show identical aggregate interference level of -118.952 dBm. This happens because there are no base stations between 32 km and 33 km from the meteorological-satellite receiver.

## Appendix 7

**Table 5. Aggregate Interference as a Function of Distance**

Protection Distance Radius (km)	Aggregate Interference Level (dBm)	Protection Distance Radius (km)	Aggregate Interference Level (dBm)	Protection Distance Radius (km)	Aggregate Interference Level (dBm)	Protection Distance Radius (km)	Aggregate Interference Level (dBm)
1	-85.9313	26	-111.239	51	-128.253	76	-138.281
2	-88.851	27	-112.02	52	-128.431	77	-139.13
3	-89.9642	28	-113.828	53	-128.864	78	-139.33
4	-92.4579	29	-115.524	54	-129.239	79	-140.259
5	-92.9459	30	-118.599	55	-129.389	80	-140.482
6	-93.7102	31	-118.649	56	-129.49	81	-142.224
7	-94.0939	32	-118.952	57	-130.158	82	-142.259
8	-95.5608	33	-118.952	58	-130.387	83	-143.981
9	-96.3417	34	-122.013	59	-130.712	84	-145.967
10	-96.7819	35	-123.063	60	-132.671	85	-146.202
11	-97.1392	36	-123.286	61	-132.935	86	-146.334
12	-97.8681	37	-124.616	62	-133.025	87	-146.366
13	-98.8411	38	-124.796	63	-133.106	88	-146.421
14	-99.4659	39	-125.088	64	-135.061	89	-153.729
15	-100.03	40	-125.507	65	-135.554	90	-154.333
16	-101.415	41	-125.822	66	-135.914	91	-154.672
17	-102.372	42	-126.43	67	-136.196	92	-155.217
18	-103.812	43	-126.77	68	-136.485	93	-155.491
19	-104.439	44	-126.838	69	-136.54	94	-155.675
20	-104.738	45	-126.952	70	-137.075	95	-157.487
21	-105.052	46	-127.38	71	-137.562	96	-157.948
22	-106.333	47	-127.431	72	-137.747	97	-163.035
23	-107.366	48	-127.786	73	-137.965	98	-164.808
24	-109.071	49	-127.82	74	-138.033	99	-166.483
25	-110.273	50	-128.139	75	-138.062		

## Appendix 7

From Table 5 using the interference protection criteria for the meteorological-satellite receiver the protection distance radius can be determined. Figure 8 shows the results from the model used to determine the protection distance. The meteorological-satellite receiver noise level is -111.5452 dBm. The meteorological-satellite receiver interference protection criteria based on an I/N of -10 dB, is -121.5452 dBm. From Table 5 the protection distance needed to meet the meteorological-satellite receiver interference protection criteria is 34 km. The large red circle in Figure 8 represents this protection distance. The base station shown by a small red circle is the closest base station to the meteorological-satellite receiver with a distance of 34.408 km.

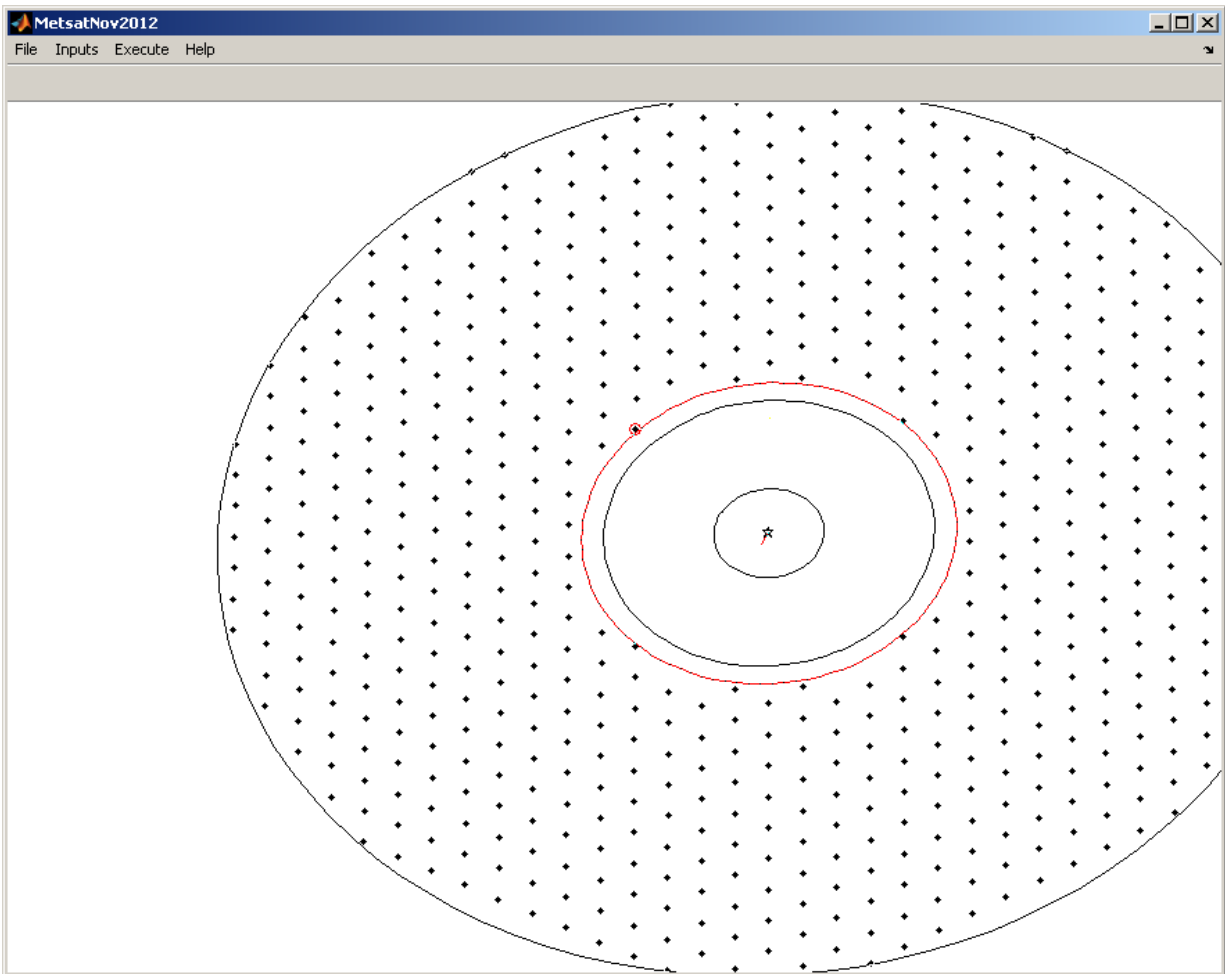

**Figure 8. Example of Protection Distance (Red Circle)**

A summary of the model output is shown in Table 6 for the meteorological-satellite receiver assessed. For each earth station location, three different scenarios were run: using a 5 MHz LTE channel, a 10 MHz LTE channel, and a 15 MHz LTE channel. Since the Working Group does not know how the channel plan the FCC is considering for the auction, the results for

## Appendix 7

all the runs are presented. The calculated protection distances in Table 6 are based on the assumption that the commercial wireless licensees will design their base stations and network lay down to control the handsets so they will not operate within the protection zones, unless otherwise coordinated and agreed, to ensure the aggregate power level from the UEs does not exceed the IPSD limit at the incumbent federal receiver.

## Appendix 7

**Table 6. Summary of Protection Distances**

		5 MHz LTE Channel			10 MHz LTE Channel			15 MHz LTE Channel		
		Protection Distance Minimum (km)	Protection Distance Mean (km)	Protection Distance Maximum (km)	Protection Distance Minimum (km)	Protection Distance Mean (km)	Protection Distance Maximum (km)	Protection Distance Minimum (km)	Protection Distance Mean (km)	Protection Distance Maximum (km)
POES/GOES	Anderson Air Force Base, Guam	37	39.5	42	37	39.5	42	37	39.5	42
POES/GOES	Elmendorf Air Force Base, AK	13	13.8	14	13	13.9	14	13	.1397	14
POES/GOES	Fairbanks, AK	59	76.7	81	65	79.3	84	73	79.7	81
POES/GOES	Kaena Point/Hickam Air Force Base/Pearl Harbor, HI	24	28.7	35	25	30.2	35	28	30.8	35
POES/GOES	Miami, FL	34	40.1	46	40	42.2	46	40	45.6	46
POES/GOES	Monterey, CA	54	78.8	88	65	82.4	85	72	83.9	85
POES/GOES	Sioux Falls, SD	30	32.1	36	32	34.5	40	34	36.3	42
POES/GOES	Stennis Space Center, MS	32	44.2	58	40	50.8	58	46	52.4	58
POES/GOES	Suitland, MD	37	44.2	58	40	50.8	58	46	52.4	58
POES/GOES	Twenty-Nine-Palms, CA	42	61.8	80	49	68.7	80	51	72.7	80
POES/GOES	Wallops Island, VA	25	27.5	29	28	29.1	30	29	29.9	30
POES/GOES	Yuma, AZ	65	73.9	95	65	78.4	95	70	79.3	95
GOES Only	Cincinnati, OH	19	26.3	32	17	26.3	32	19	26.3	32
GOES Only	Omaha, NE	11	22.7	30	12	22.6	30	12	23.1	30
GOES Only	Rock Island, IL	5	7.9	14	5	8	10	5	7.9	19
GOES Only	Sacramento, CA	21	31.7	55	20	30.3	55	21	30.5	55
GOES Only	St. Louis, MO	13	17.2	27	14	17.2	34	13	17.1	29
GOES Only	Vicksburg, MS	4	9.7	16	5	9.6	14	6	9.6	15



## METEOROLOGICAL-SATELLITE RECEIVE STATION PROTECTION DISTANCES

### INTRODUCTION

This appendix provides the detailed meteorological-satellite receiver protection distances. The analysis considered channel bandwidths of 5 MHz, 10 MHz, and 15 MHz. The protection distances for each meteorological-satellite receiver were computed for various iterations of the analysis model randomizing the equivalent isotropically radiated power levels and the location of the user equipment (UE). Randomizing the UE location also varies the meteorological-satellite receive antenna gain.

### METEOROLOGICAL-SATELLITE RECEIVER PROTECTION DISTANCES

#### Meteorological-Satellite Receive Protection Distances - 5 MHz Channel Bandwidth

The protection distances for the Wallops Island meteorological-satellite receive station are shown in Table D-1 and Figure D-1.

**Table D-1. Wallops Island Protection Distances**

Number of Iterations	Minimum Distance (km)	Mean Distance (km)	Maximum Distance (km)
1	28	28	28
10	27	27.6	28
100	26	27.4	29
500	25	27.5	29

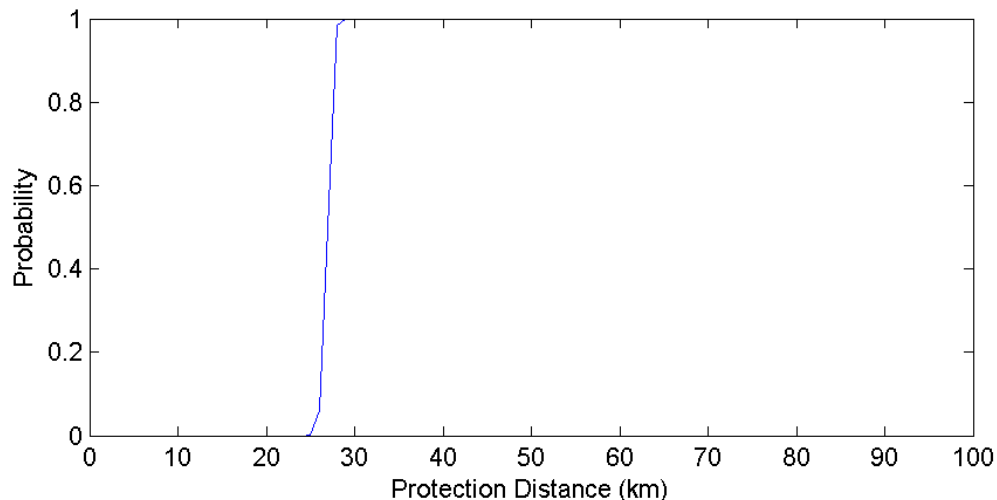

**Figure D-1. Wallops Island Protection Distances (500 Iterations)**

The protection distances for the Fairbanks meteorological-satellite receive station are shown in Table D-2 and Figure D-2.

## Appendix 7

**Table D-2. Fairbanks Protect Distances**

Number of Iterations	Minimum Distance (km)	Mean Distance (km)	Maximum Distance (km)
1	73	73	73
10	59	76.6	80
100	59	76.2	80
500	59	76.7	81

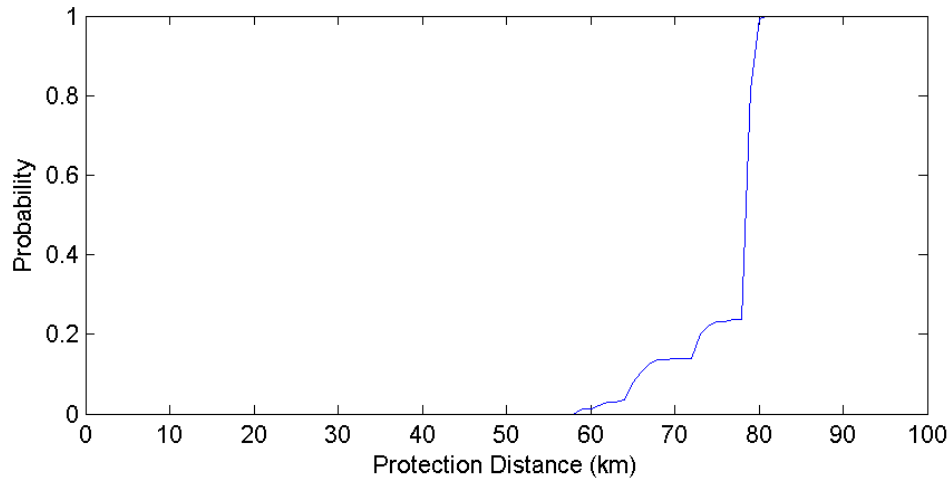

**Figure D-2. Fairbanks Protection Distances (500 Iterations)**

The protection distances for the Suitland meteorological-satellite receive station are shown in Table D-3 and Figure D-3.

**Table D-3. Suitland Protection Distances**

Number of Iterations	Minimum Distance (km)	Mean Distance (km)	Maximum Distance (km)
1	43	43	43
10	41	57.3	80
100	41	60.1	80
500	37	60.1	91
1000	37	59.42	91

## Appendix 7

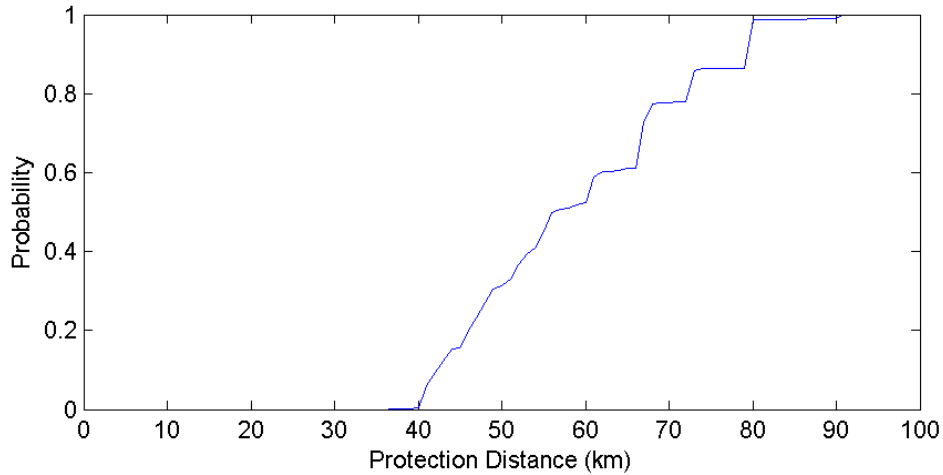
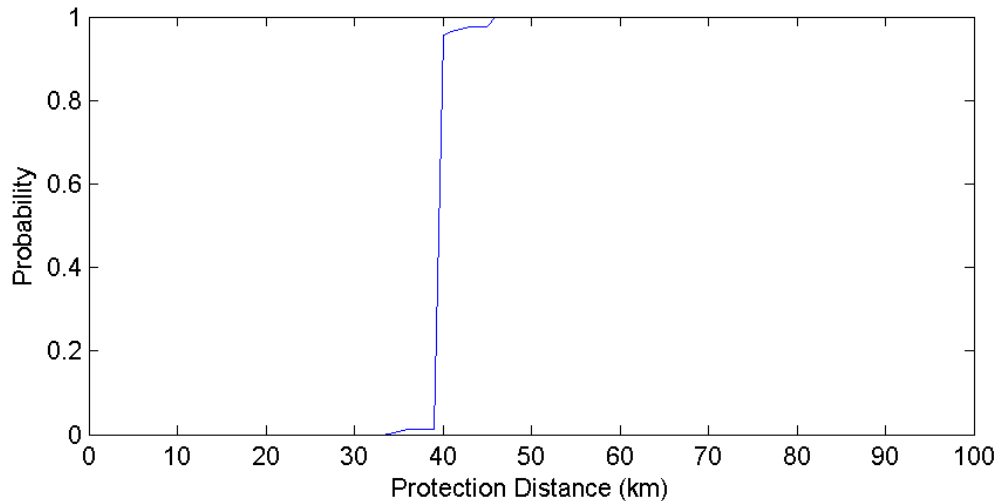

**Figure D-3. Suitland Protection Distances (1000 Iterations)**

The protection distances for the Miami meteorological-satellite receive station are shown in Table D-4 and Figure D-4.

**Table D-4. Miami Protection Distances**

Number of Iterations	Minimum Distance (km)	Mean Distance (km)	Maximum Distance (km)
1	40	40	40
10	40	40	40
100	35	39.9	46
500	34	40.1	46



**Figure D-4. Miami Protection Distances (500 Iterations)**

The protection distances for the Ford Island/Pearl Harbor meteorological-satellite receive station are shown in Table D-5 and Figure D-5.

## Appendix 7

**Table D-5. Ford Island/Pearl Harbor Protection Distances**

Number of Iterations	Minimum Distance (km)	Mean Distance (km)	Maximum Distance (km)
1	25	25	25
10	18	23.5	25
100	17	23.6	25
500	17	23.5	25

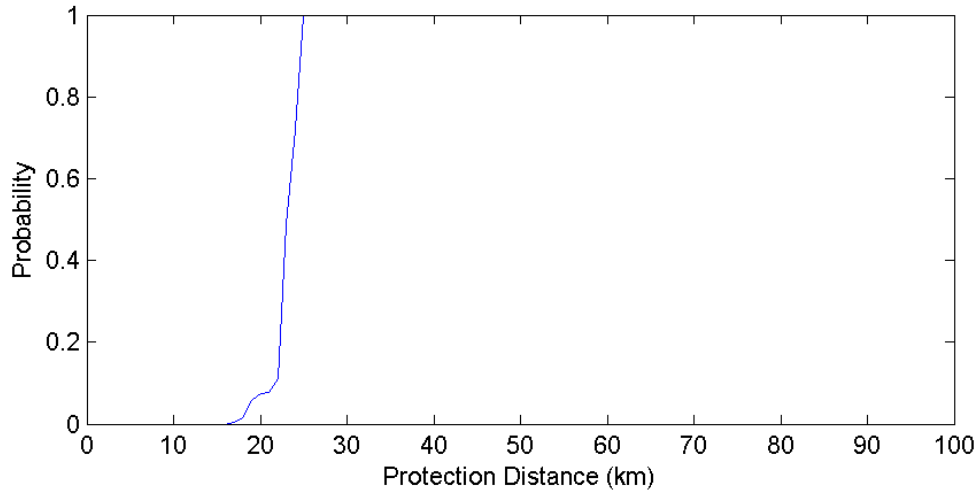

**Figure D-5. Ford Island/Pearl Harbor Protection Distances (500 Iterations)**

The protection distances for the Sioux Falls meteorological-satellite receive station are shown in Table D-6 and Figure D-6.

**Table D-6. Sioux Falls Protection Distances**

Number of Iterations	Minimum Distance (km)	Mean Distance (km)	Maximum Distance (km)
1	34	34	34
10	30	31.8	34
100	30	32	34
500	30	32.1	36

## Appendix 7

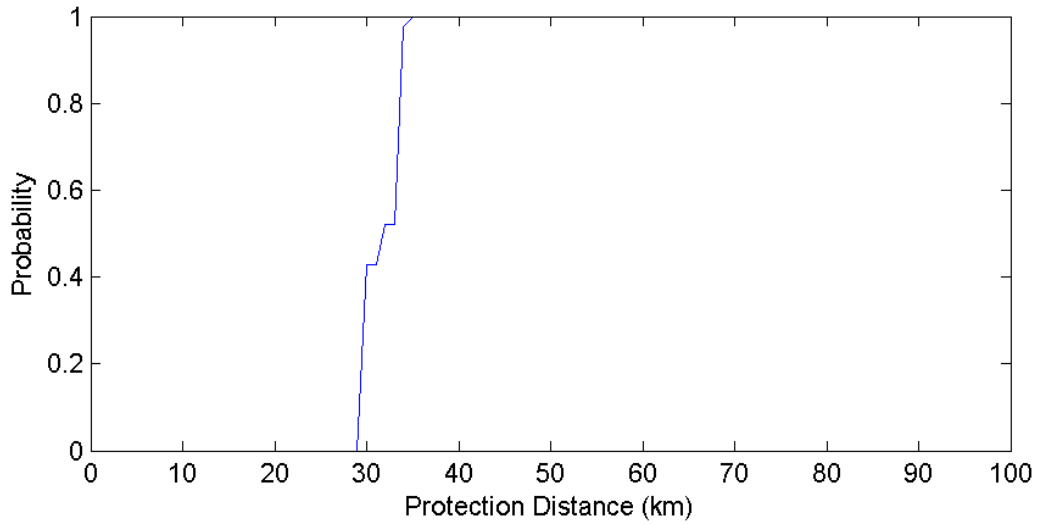
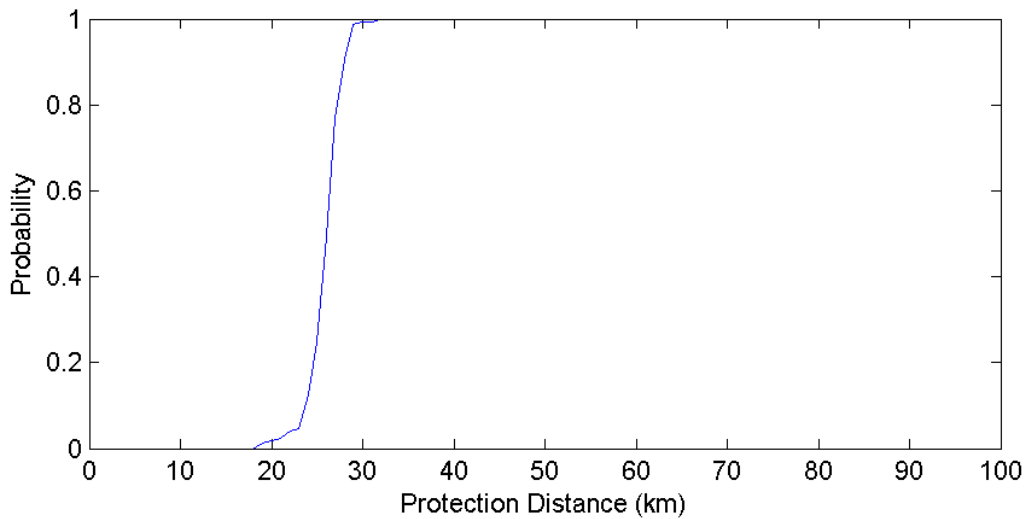

**Figure D-5. Sioux Falls Protection Distances (500 Iterations)**

The protection distances for the Cincinnati meteorological-satellite receive station are shown in Table D-7 and Figure D-7.

**Table D-7. Cincinnati Protection Distances**

<b>Number of Iterations</b>	<b>Minimum Distance (km)</b>	<b>Mean Distance (km)</b>	<b>Maximum Distance (km)</b>
1	26	26	26
10	24	26.6	29
100	24	26.8	32
500	19	26.3	32



**Figure D-7. Cincinnati Protection Distances (500 Iterations)**

## Appendix 7

The protection distances for the Rock Island meteorological-satellite receive station are shown in Table D-8 and Figure D-8.

**Table D-8. Rock Island Protection Distances**

Number of Iterations	Minimum Distance (km)	Mean Distance (km)	Maximum Distance (km)
1	8	8	8
10	5	7.6	9
100	5	7.8	14
500	5	7.9	14

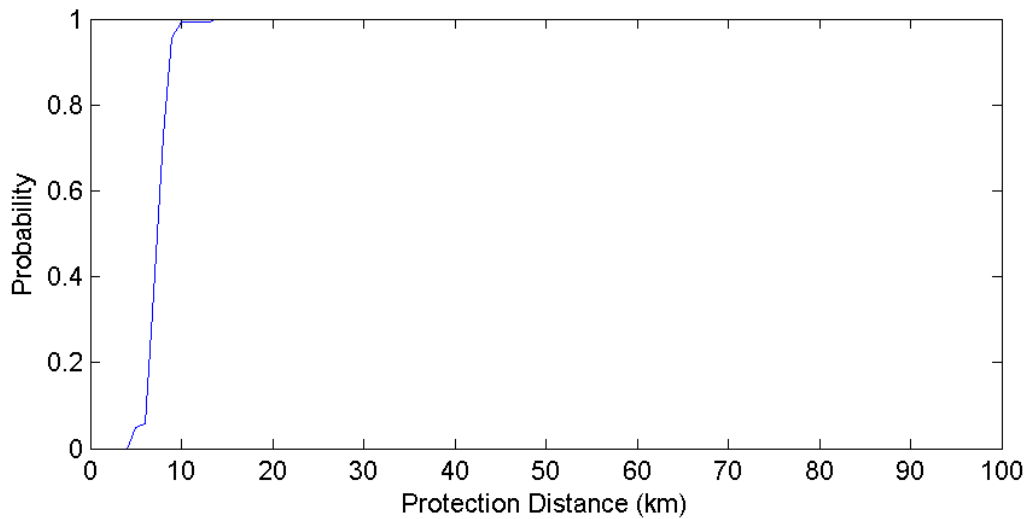

**Figure D-8. Rock Island Protection Distances (500 Iterations)**

The protection distances for the Saint Louis meteorological-satellite receive station are shown in Table D-9 and Figure D-9.

**Table D-9. Saint Louis Protection Distances**

Number of Iterations	Minimum Distance (km)	Mean Distance (km)	Maximum Distance (km)
1	16	16	16
10	16	17.1	21
100	14	17.4	27
500	13	17.2	27

## Appendix 7

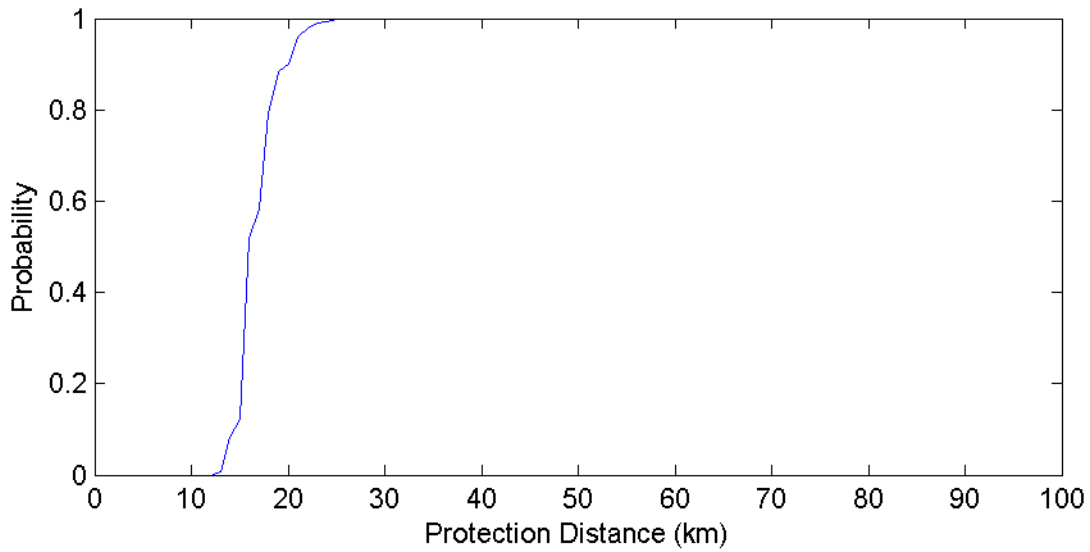
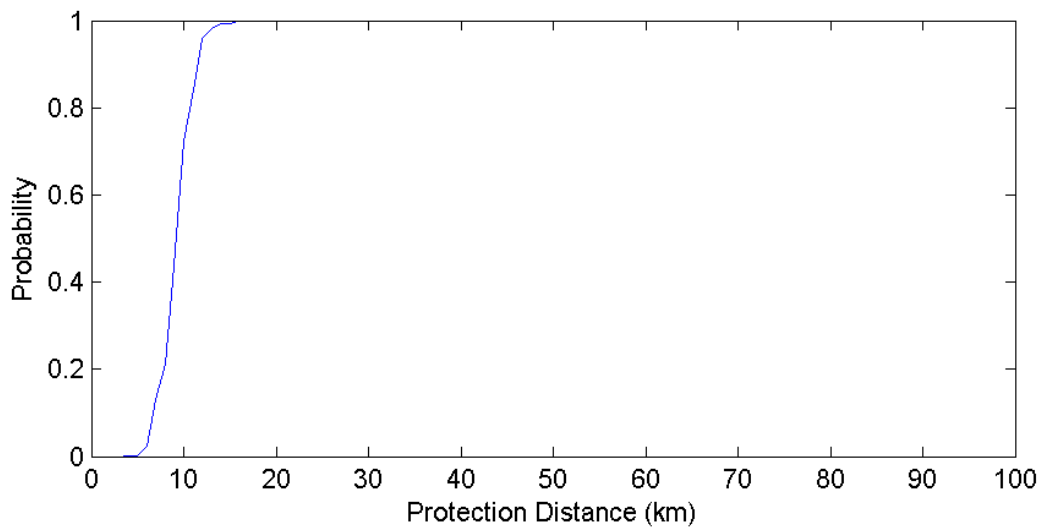

**Figure D-9. Saint Louis Protection Distances (500 Iterations)**

The protection distances for the Vicksburg meteorological-satellite receive station are shown in Table D-10 and Figure D-10.

**Table D-10. Vicksburg Protection Distances**

Number of Iterations	Minimum Distance (km)	Mean Distance (km)	Maximum Distance (km)
1	9	9	9
10	9	10.3	12
100	6	9.9	16
500	4	9.7	16



**Figure D-10. Vicksburg Protection Distances (500 Iterations)**

## Appendix 7

The protection distances for the Omaha meteorological-satellite receive station are shown in Table D-11 and Figure D-11.

**Table D-11. Omaha Protection Distances**

Number of Iterations	Minimum Distance (km)	Mean Distance (km)	Maximum Distance (km)
1	25	25	25
10	15	20.4	28
100	13	22.2	30
500	11	22.7	30

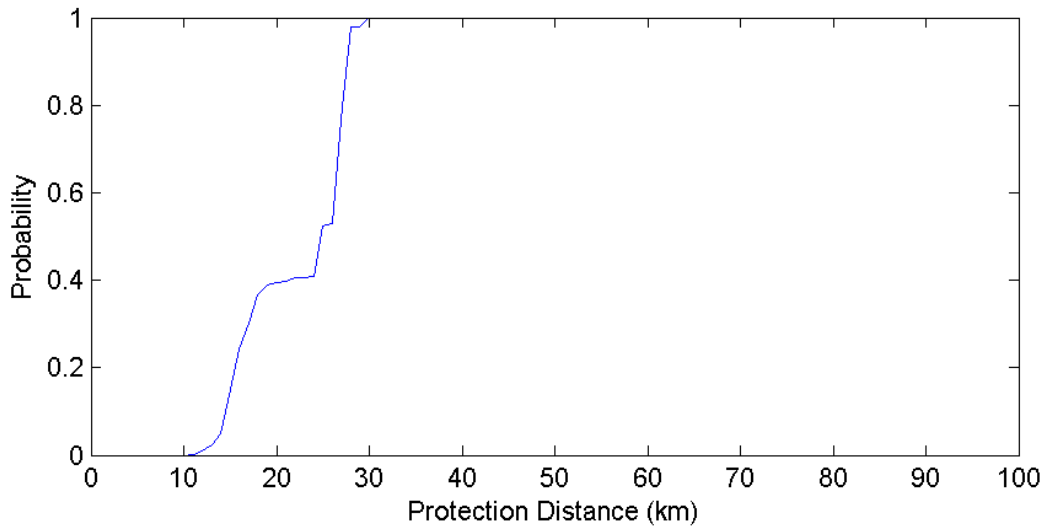

**Figure D-11. Omaha Protection Distances (500 Iterations)**

The protection distances for the Sacramento meteorological-satellite receive station are shown in Table D-12 and Figure D-12.

**Table D-12. Sacramento Protection Distances**

Number of Iterations	Minimum Distance (km)	Mean Distance (km)	Maximum Distance (km)
1	32	32	32
10	22	29	52
100	22	33.5	55
500	21	31.7	55



## Appendix 7

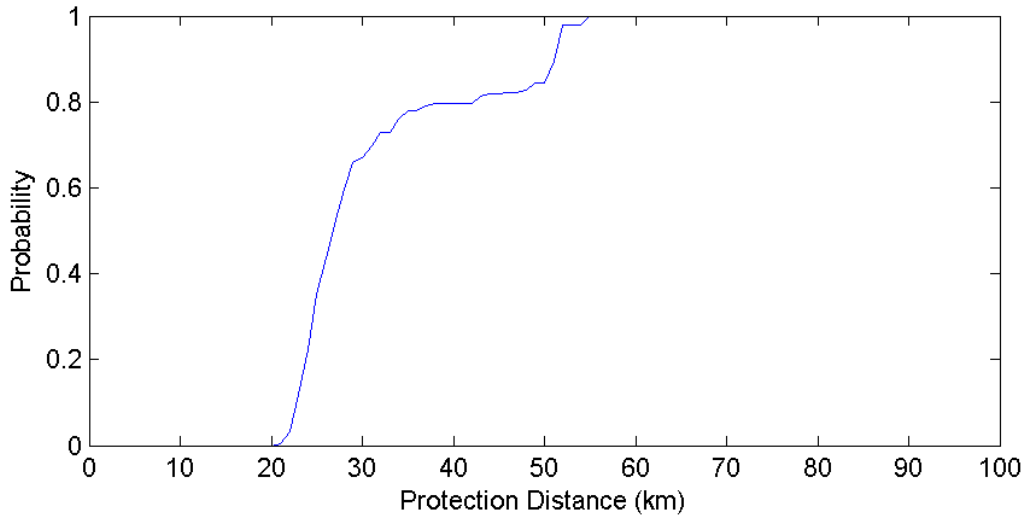
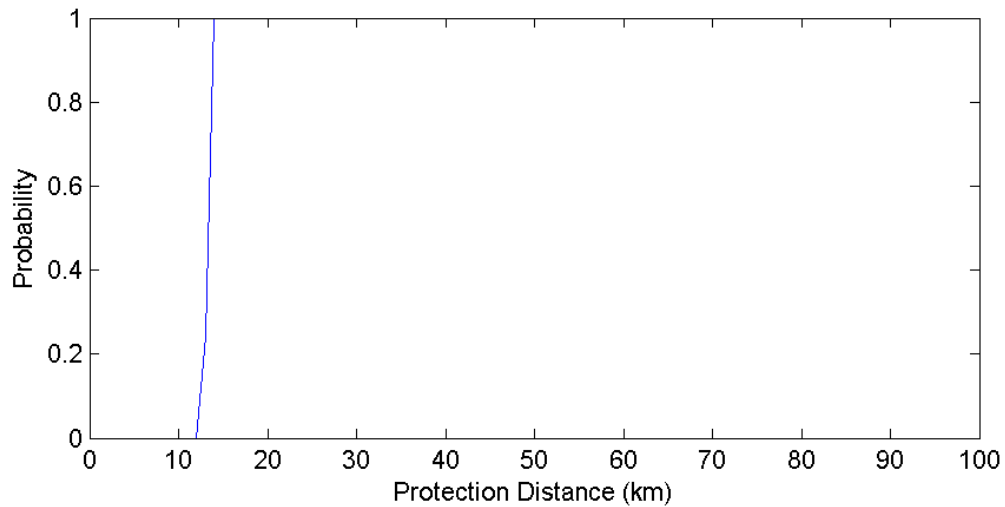

**Figure D-12. Sacramento Protection Distances (500 Iterations)**

The protection distances for the Elmendorf meteorological-satellite receive station are shown in Table D-13 and Figure D-13.

**Table D-13. Elmendorf Protection Distances**

Number of Iterations	Minimum Distance (km)	Mean Distance (km)	Maximum Distance (km)
1	13	13	13
10	13	13.5	14
100	13	13.7	14
500	13	13.8	14



**Figure D-13. Elmendorf Protection Distances (500 Iterations)**

## Appendix 7

The protection distances for the Monterey meteorological-satellite receive station are shown in Table D-14 and Figure D-14.

**Table D-14. Monterey Protection Distances**

Number of Iterations	Minimum Distance (km)	Mean Distance (km)	Maximum Distance (km)
1	77	77	77
10	64	78	85
100	61	79.3	85
500	54	78.8	88

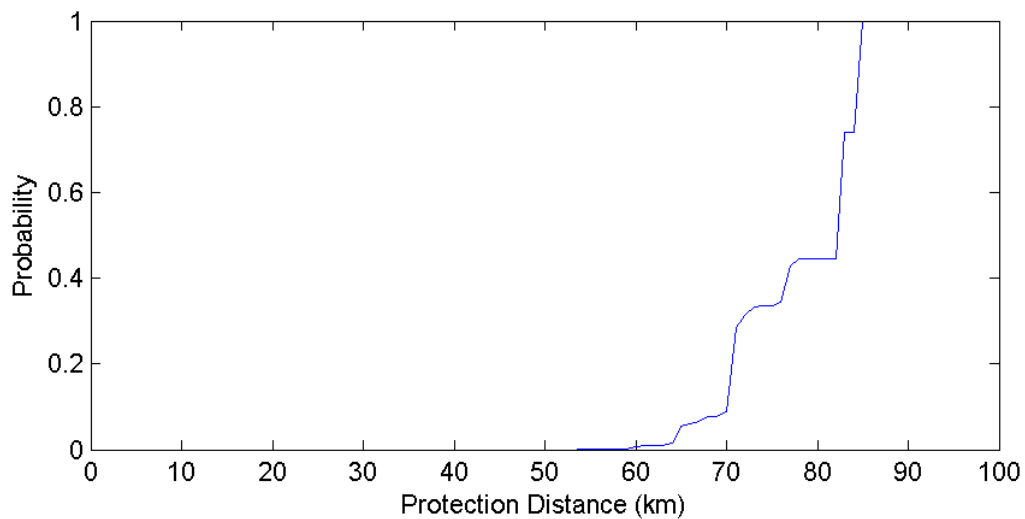

**Figure D-14. Monterey Protection Distances (500 Iterations)**

The protection distances for the Stennis meteorological-satellite receive station are shown in Table D-15 and Figure D-15.

**Table D-15. Stennis Protection Distances**

Number of Iterations	Minimum Distance (km)	Mean Distance (km)	Maximum Distance (km)
1	35	35	35
10	34	43.8	52
100	34	43.9	58
500	32	44.2	58

## Appendix 7

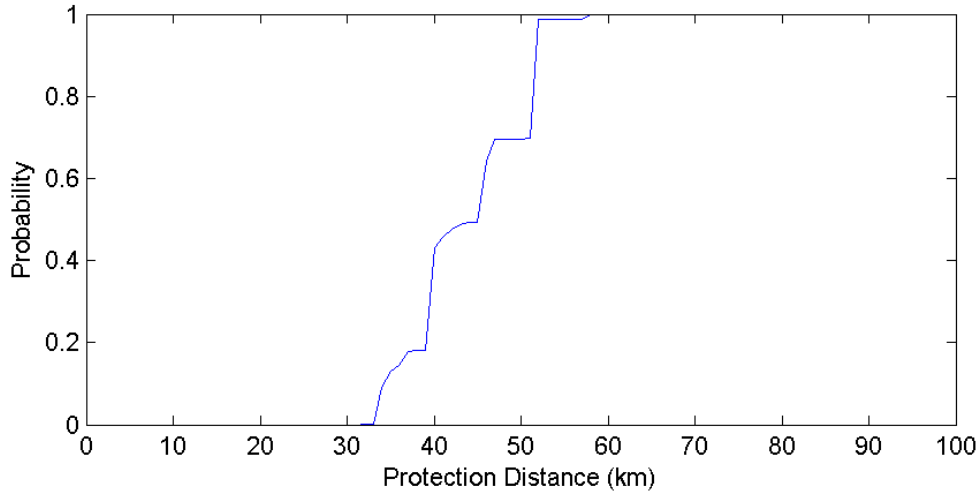
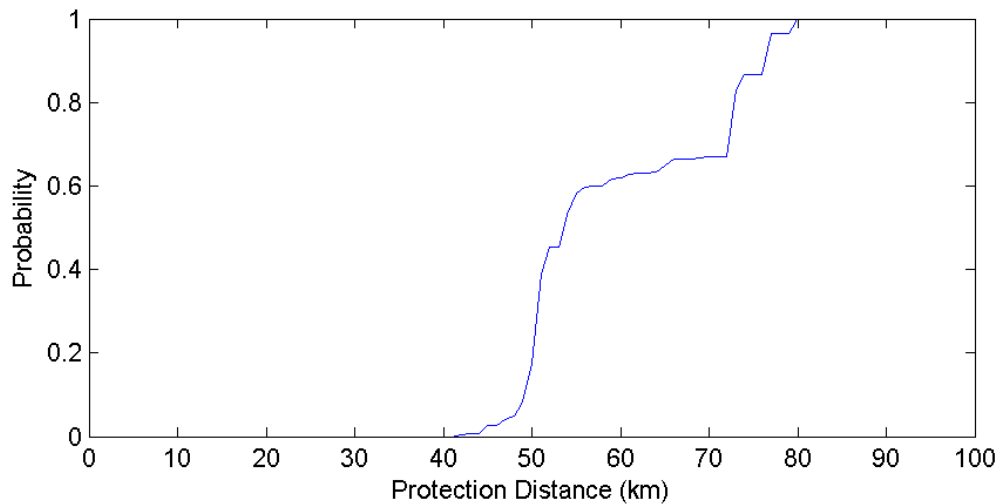

**Figure D-15. Stennis Protection Distances (500 Iterations)**

The protection distances for the Twenty-Nine Palms meteorological-satellite receive station are shown in Table D-16 and Figure D-16.

**Table D-16. Twenty-Nine Palms Protection Distances**

Number of Iterations	Minimum Distance (km)	Mean Distance (km)	Maximum Distance (km)
1	77	77	77
10	51	66.8	80
100	42	61.8	80
500	42	61.8	80
1000	42	61.8	80



**Figure D-16. Twenty-Nine Palms Protection Distances (1000 Iterations)**

## Appendix 7

The protection distances for the Yuma meteorological-satellite receive station are shown in Table D-17 and Figure D-17.

**Table D-17. Yuma Protection Distances**

Number of Iterations	Minimum Distance (km)	Mean Distance (km)	Maximum Distance (km)
1	70	70	70
10	70	72.8	94
100	65	74.1	95
500	65	73.9	95

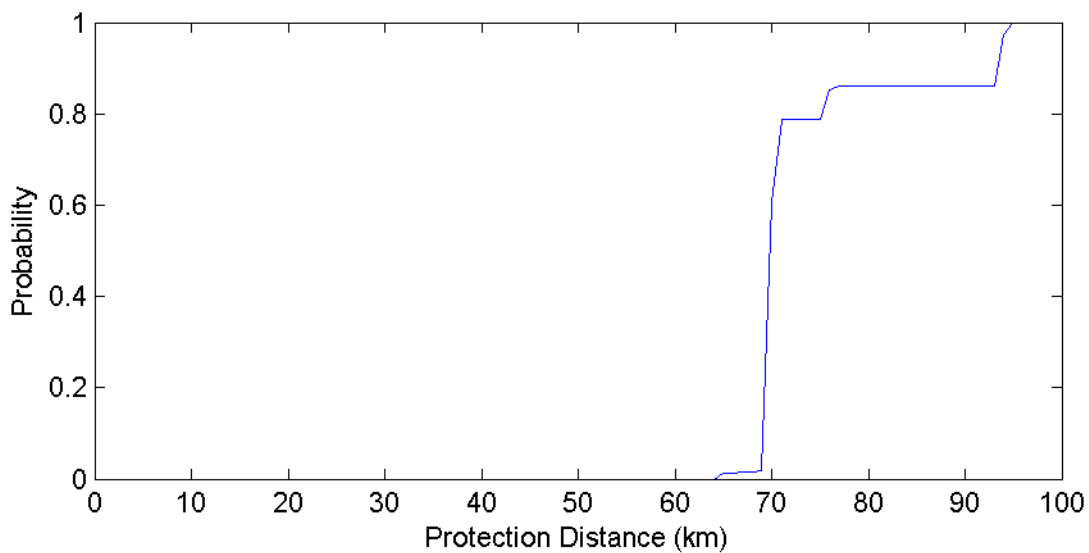

**Figure D-17. Yuma Protection Distances (500 Iterations)**

The protection distances for the Anderson meteorological-satellite receive station are shown in Table D-18.

**Table D-18. Anderson Protection Distances**

Number of Iterations	Minimum Distance (km)	Mean Distance (km)	Maximum Distance (km)
1	42	42	42
10	37	39.5	42
100	37	39.5	42
500	37	39.5	42

**Meteorological-Satellite Receive Protection Distances - 10 MHz Channel Bandwidth**

## Appendix 7

The protection distances for the Wallops Island meteorological-satellite receive station are shown in Table D-19 and Figure D-19.

**Table D-19. Wallops Island Protection Distances**

Number of Iterations	Minimum Distance (km)	Mean Distance (km)	Maximum Distance (km)
1	30	30	30
10	29	29	29
100	28	29.1	30
500	28	29.1	30

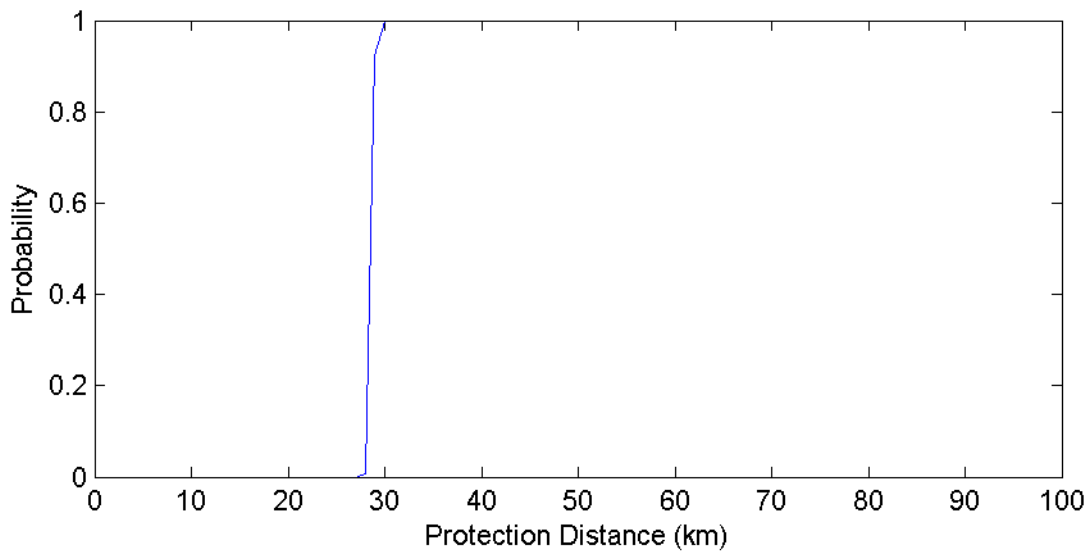

**Figure D-19. Wallops Island Protection Distances (500 Iterations)**

The protection distances for the Fairbanks meteorological-satellite receive station are shown in Table D-20 and Figure D-20.

**Table D-20. Fairbanks Protection Distances**

Number of Iterations	Minimum Distance (km)	Mean Distance (km)	Maximum Distance (km)
1	78	78	78
10	79	79.3	80
100	68	79.34	81
500	65	79.3	84

## Appendix 7

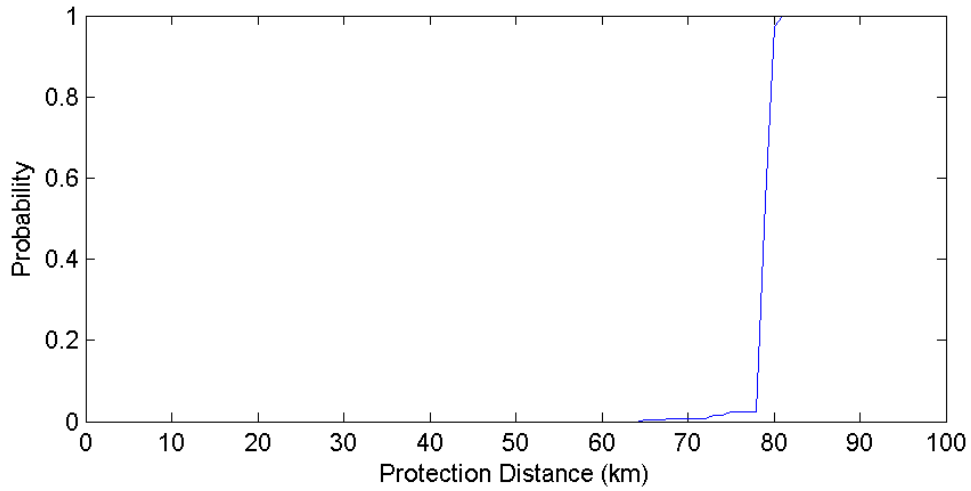
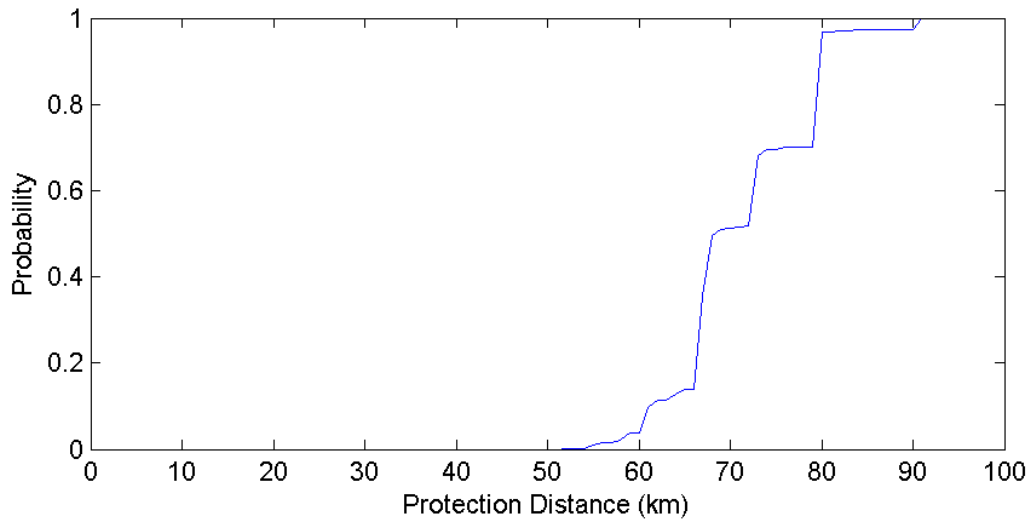

**Figure D-20. Fairbanks Protection Distances (500 Iterations)**

The protection distances for the Suitland meteorological-satellite receive station are shown in Table D-21 and Figure D-21.

**Table D-21. Suitland Protection Distances**

Number of Iterations	Minimum Distance (km)	Mean Distance (km)	Maximum Distance (km)
1	80	80	80
10	64	73.9	80
100	57	71.47	91
500	56	72.2	91
1000	52	72.25	91



**Figure D-21. Suitland Protection Distances (500 Iterations)**

## Appendix 7

The protection distances for the Miami meteorological-satellite receive station are shown in Table D-22 and Figure D-22.

**Table D-22. Miami Protection Distances**

Number of Iterations	Minimum Distance (km)	Mean Distance (km)	Maximum Distance (km)
1	44	44	44
10	40	42.4	46
100	40	43.03	46
500	40	42.2	46

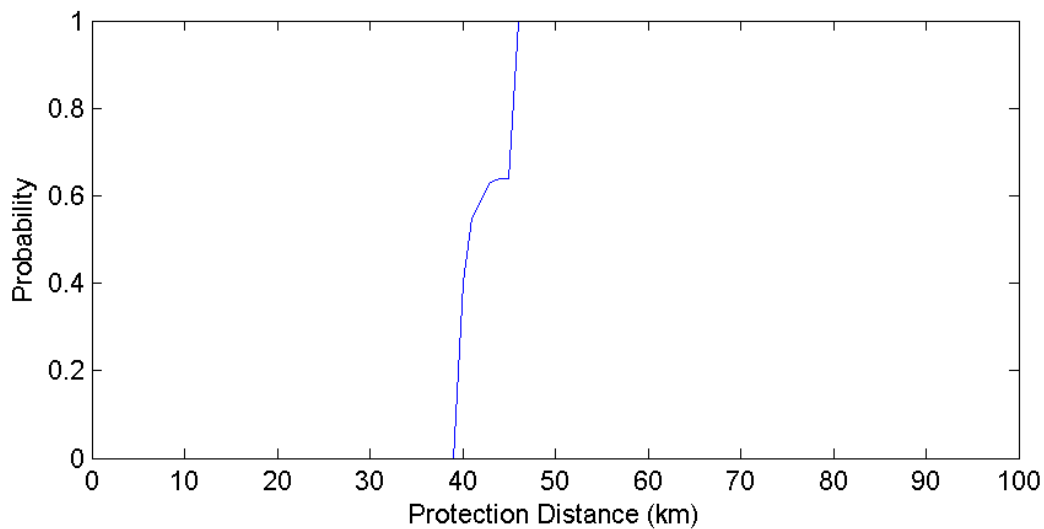

**Figure D-22. Miami Protection Distances (500 Iterations)**

The protection distances for the Ford Island/Pearl Harbor meteorological-satellite receive station are shown in Table D-23 and Figure D-23.

**Table D-23. Ford Island/Pearl Harbor Protection Distances**

Number of Iterations	Minimum Distance (km)	Mean Distance (km)	Maximum Distance (km)
1	25	25	25
10	23	24.3	25
100	23	24.5	25
500	23	24.8	25

## Appendix 7

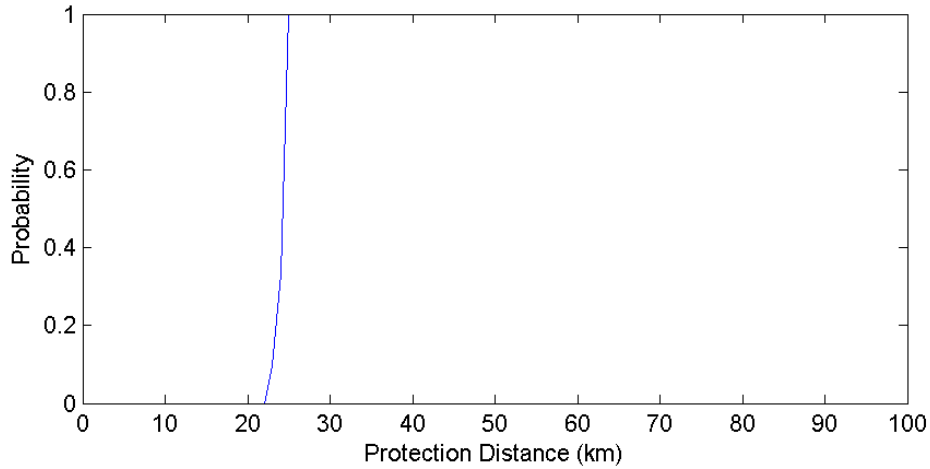
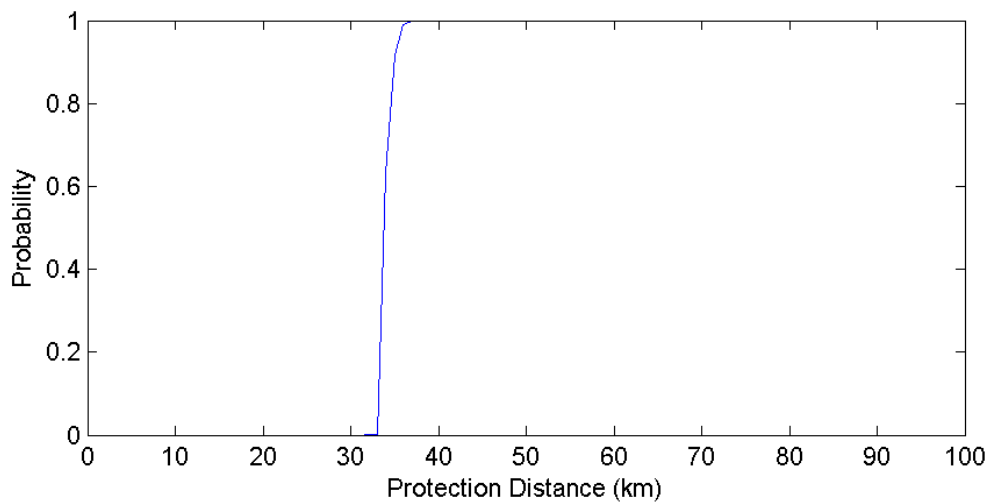

**Figure D-23. Ford Island/Pearl Harbor Protection Distances (500 Iterations)**

The protection distances for the Sioux Falls meteorological-satellite receive station are shown in Table D-24 and Figure D-24.

**Table D-24. Sioux Falls Protection Distances**

Number of Iterations	Minimum Distance (km)	Mean Distance (km)	Maximum Distance (km)
1	34	34	34
10	34	35	37
100	32	34.4	37
500	32	34.5	39
5000	32	34.5	40



**Figure D-24. Sioux Falls Protection Distances (500 Iterations)**



## Appendix 7

The protection distances for the Cincinnati meteorological-satellite receive station are shown in Table D-25 and Figure D-25.

**Table D-25. Cincinnati Protection Distances**

Number of Iterations	Minimum Distance (km)	Mean Distance (km)	Maximum Distance (km)
1	25	25	25
10	20	26.1	29
100	20	26.4	32
500	17	26.3	32

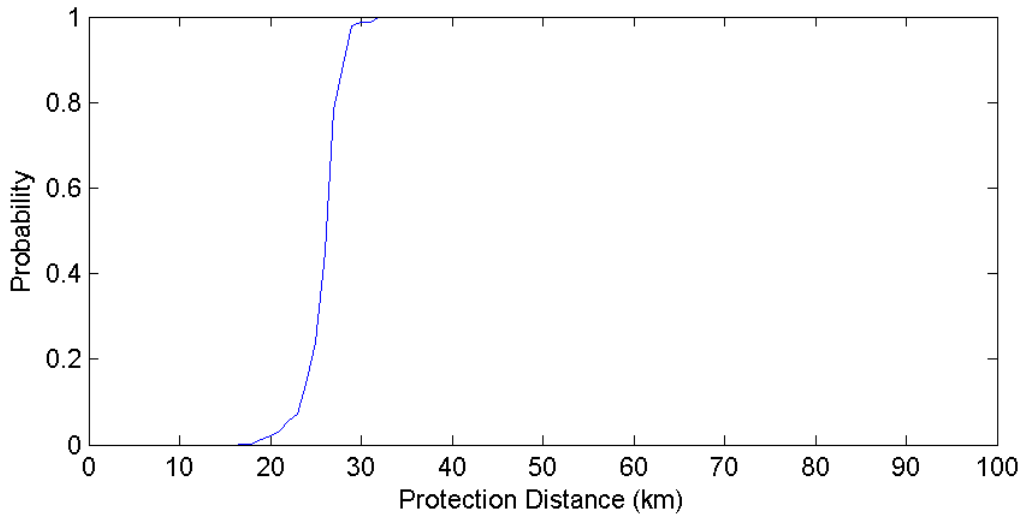

**Figure D-25. Cincinnati Protection Distances (500 Iterations)**

The protection distances for the Rock Island meteorological-satellite receive station are shown in Table D-26 and Figure D-26.

**Table D-26. Rock Island Protection Distances**

Number of Iterations	Minimum Distance (km)	Mean Distance (km)	Maximum Distance (km)
1	7	7	7
10	7	8	10
100	5	7.9	10
500	5	8	10

## Appendix 7

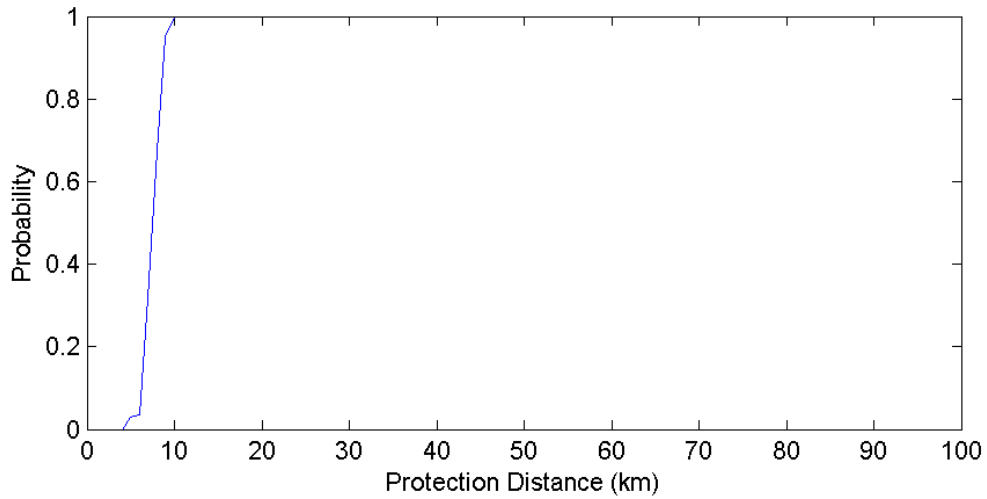
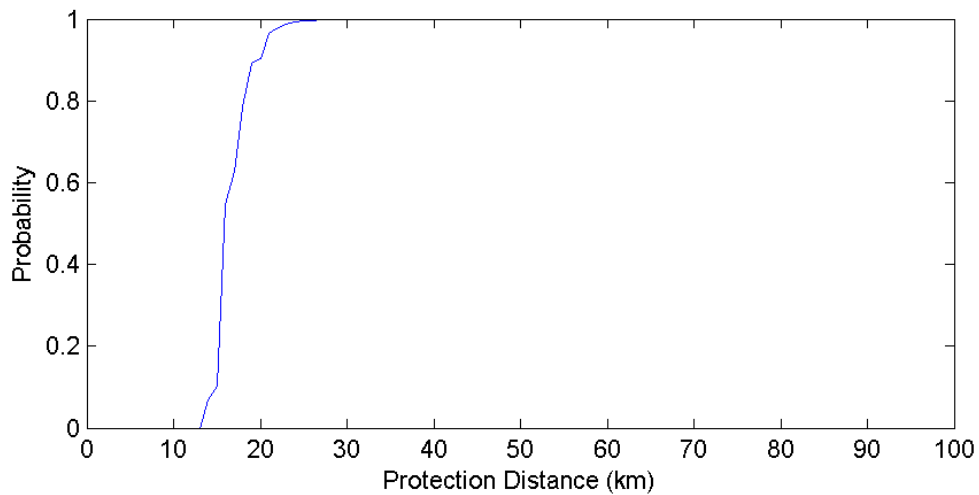

**Figure D-26. Rock Island Protection Distances (500 Iterations)**

The protection distances for the Saint Louis meteorological-satellite receive station are shown in Table D-27 and Figure D-27.

**Table D-27. Saint Louis Protection Distances**

Number of Iterations	Minimum Distance (km)	Mean Distance (km)	Maximum Distance (km)
1	16	16	16
10	16	17.7	22
100	14	17	24
500	14	17.2	34



**Figure D-27. Saint Louis Protection Distances (500 Iterations)**

## Appendix 7

The protection distances for the Vicksburg meteorological-satellite receive station are shown in Table D-28 and Figure D-28.

**Table D-28. Vicksburg Protection Distances**

Number of Iterations	Minimum Distance (km)	Mean Distance (km)	Maximum Distance (km)
1	10	10	10
10	7	10	13
100	7	9.6	14
500	5	9.6	14

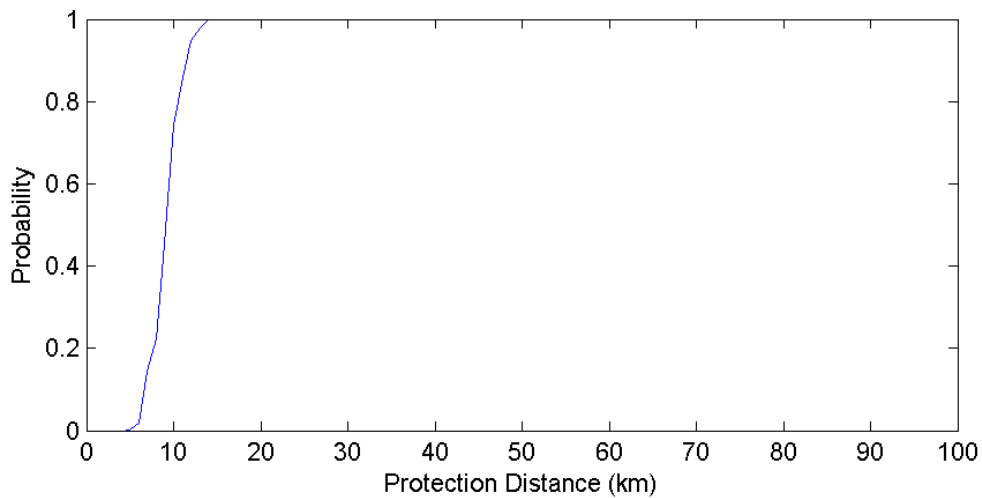

**Figure D-28. Vicksburg Protection Distances (500 Iterations)**

The protection distances for the Omaha meteorological-satellite receive station are shown in Table D-29 and Figure D-29.

**Table D-29. Omaha Protection Distances**

Number of Iterations	Minimum Distance (km)	Mean Distance (km)	Maximum Distance (km)
1	25	25	25
10	15	20.9	28
100	12	21.6	28
500	12	22.6	30

## Appendix 7

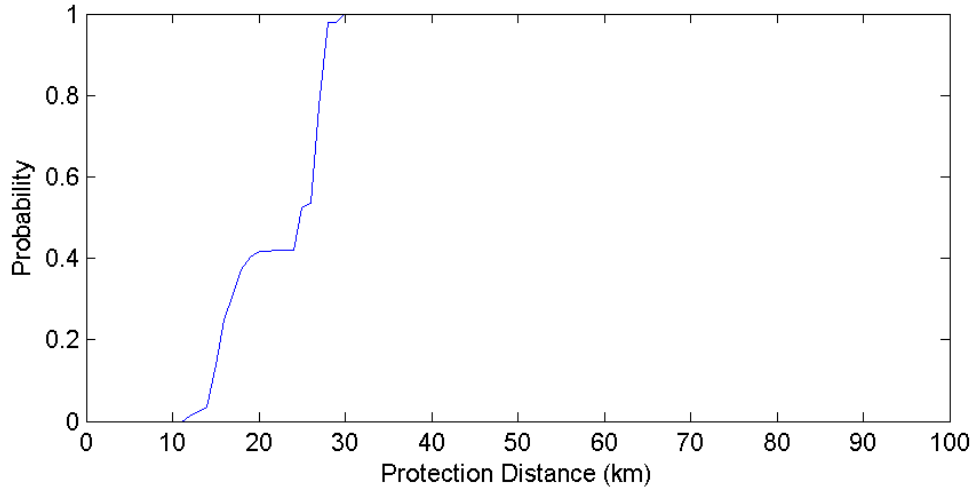
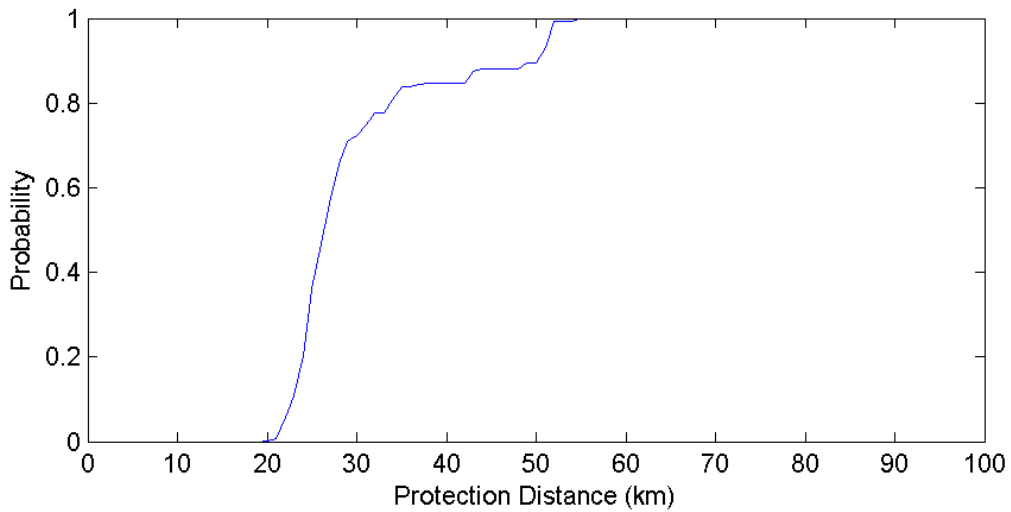

**Figure D-29. Omaha Protection Distances (500 Iterations)**

The protection distances for the Sacramento meteorological-satellite receive station are shown in Table D-30 and Figure D-30.

**Table D-30. Sacramento Protection Distances**

<b>Number of Iterations</b>	<b>Minimum Distance (km)</b>	<b>Mean Distance (km)</b>	<b>Maximum Distance (km)</b>
1	35	35	35
10	24	29.9	52
100	22	31.6	52
500	20	30.3	55



## Appendix 7

**Figure D-30. Sacramento Protection Distances (500 Iterations)**

The protection distances for the Elmendorf meteorological-satellite receive station are shown in Table D-31 and Figure D-31.

**Table D-31. Elmendorf Protection Distances**

Number of Iterations	Minimum Distance (km)	Mean Distance (km)	Maximum Distance (km)
1	13	13	13
10	13	13.9	14
100	13	13.9	14
500	13	13.9	14

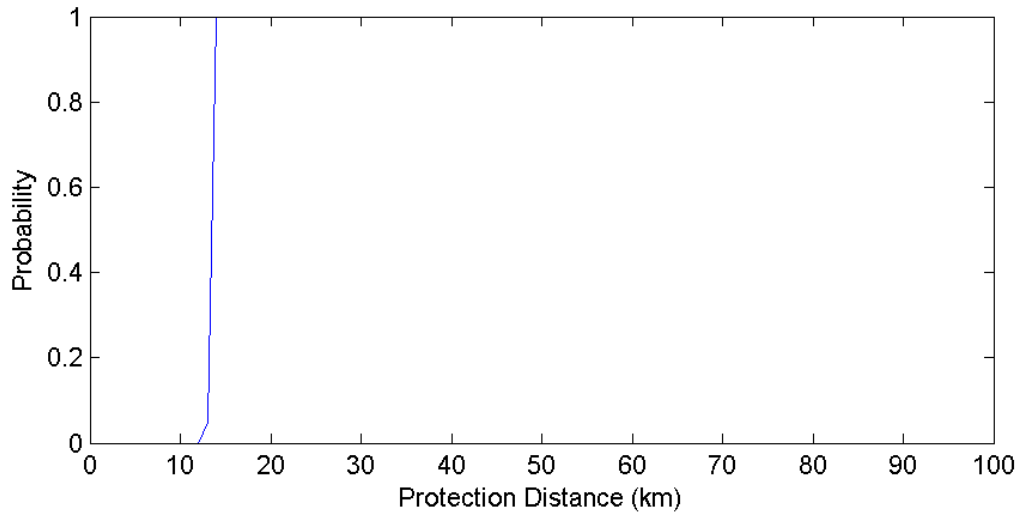

**Figure D-31. Elmendorf Protection Distances (500 Iterations)**

The protection distances for the Monterey meteorological-satellite receive station are shown in Table D-32 and Figure D-32.

**Table D-32. Monterey Protection Distances**

Number of Iterations	Minimum Distance (km)	Mean Distance (km)	Maximum Distance (km)
1	84	84	84
10	71	82.4	85
100	71	82.45	85
500	65	82.4	85

## Appendix 7

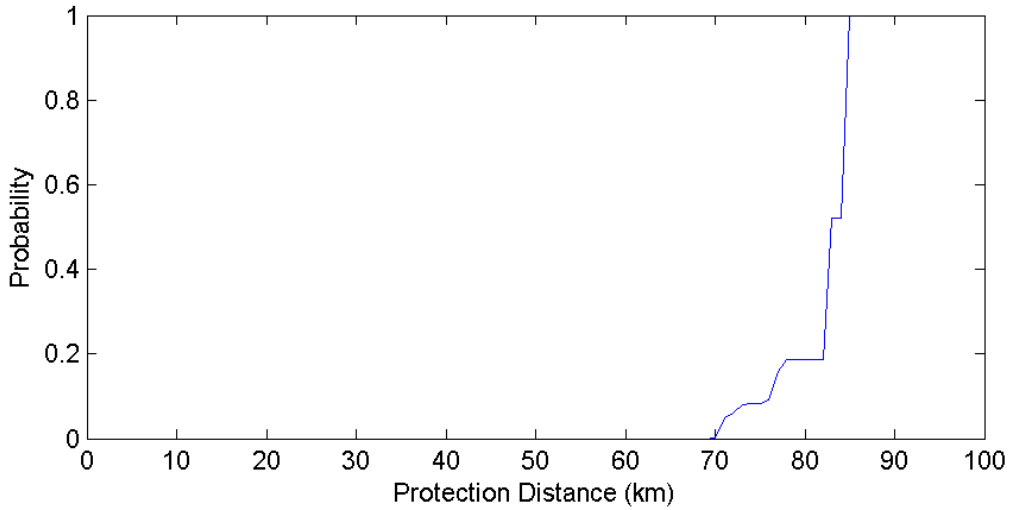

**Figure D-32. Monterey Protection Distances (500 Iterations)**

The protection distances for the Stennis meteorological-satellite receive station are shown in Table D-33 and Figure D-33.

**Table D-33. Stennis Protection Distances**

<b>Number of Iterations</b>	<b>Minimum Distance (km)</b>	<b>Mean Distance (km)</b>	<b>Maximum Distance (km)</b>
1	51	51	51
10	51	51.9	52
100	41	51.2	58
500	40	50.8	58

The protection distances for the Stennis meteorological-satellite receive station are shown in Table D-34 and Figure D-34.

## Appendix 7

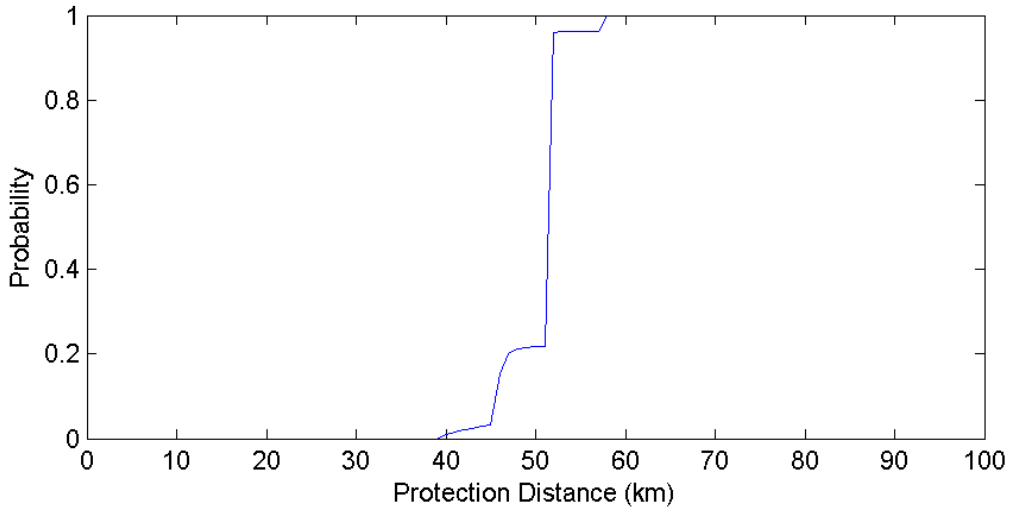

**Figure D-33. Stennis Protection Distances (500 Iterations)**

**Table D-34. Twenty-Nine Palms Protection Distances**

Number of Iterations	Minimum Distance (km)	Mean Distance (km)	Maximum Distance (km)
1	54	54	54
10	54	66.5	80
100	50	69.02	80
500	49	68.7	80

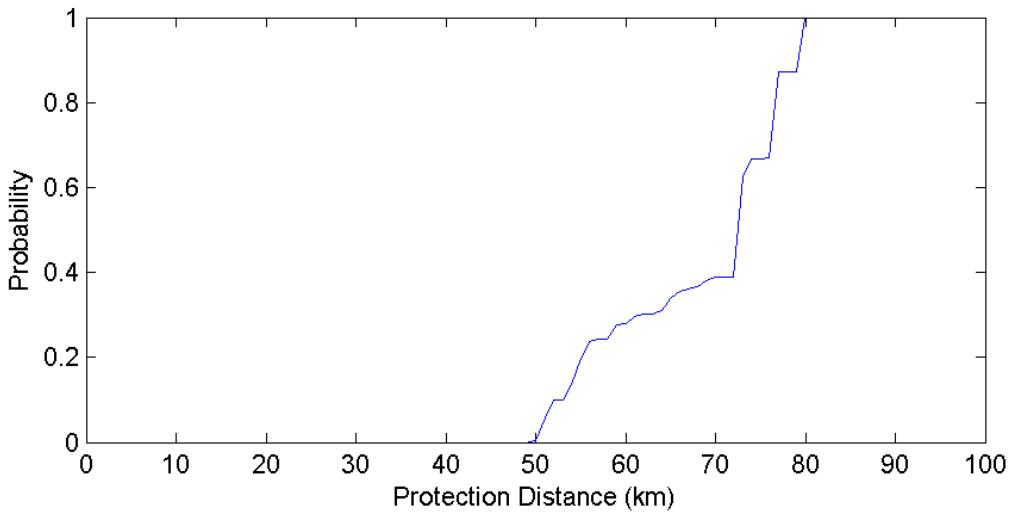

**Figure D-34. Twenty-Nine Palms Protection Distances (500 Iterations)**

## Appendix 7

The protection distances for the Yuma meteorological-satellite receive station are shown in Table D-35 and Figure D-35.

**Table D-35. Yuma Protection Distances**

Number of Iterations	Minimum Distance (km)	Mean Distance (km)	Maximum Distance (km)
1	93	93	93
10	70	74	94
100	70	75.7	95
500	65	78.4	95

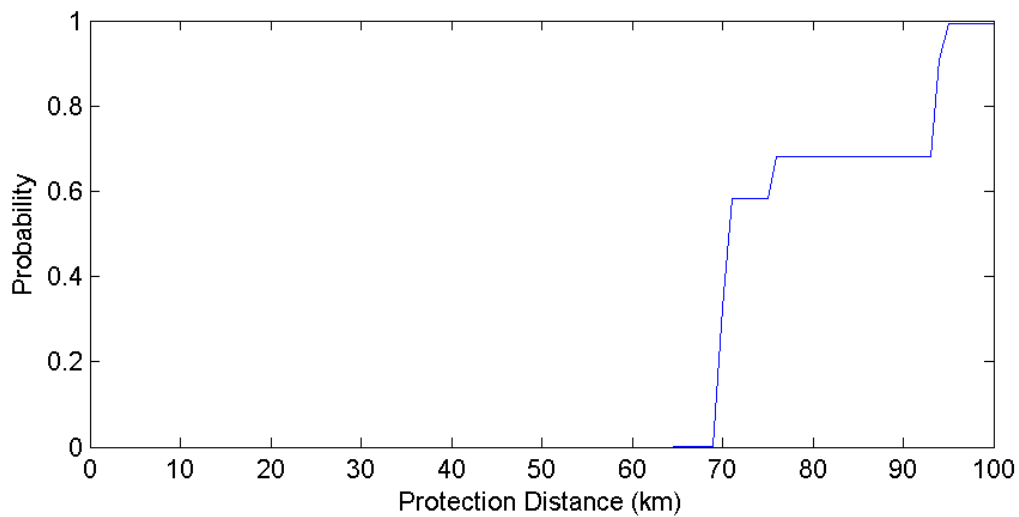

**Figure D-35. Yuma Protection Distances (500 Iterations)**

The protection distances for the Anderson meteorological-satellite receive station are shown in Table D-36.

**Table D-36. Anderson Protection Distances**

Number of Iterations	Minimum Distance (km)	Mean Distance (km)	Maximum Distance (km)
1	42	42	42
10	37	39.5	42
100	37	39.5	42
500	37	39.5	42



## Appendix 7

### Meteorological-Satellite Receive Protection Distances - 15 MHz Channel Bandwidth

The protection distances for the Wallops Island meteorological-satellite receive station are shown in Table D-37 and Figure D-37.

**Table D-37. Wallops Island Protection Distances**

Number of Iterations	Minimum Distance (km)	Mean Distance (km)	Maximum Distance (km)
1	30	30	30
10	30	30	30
100	29	29.9	30
500	29	29.9	30

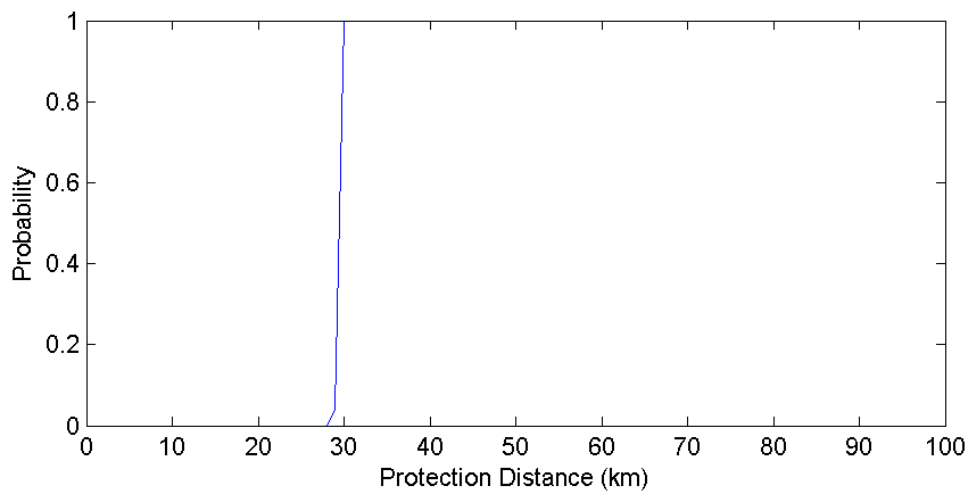

**Figure D-37. Wallops Island Protection Distances (500 Iterations)**

The protection distances for the Fairbanks meteorological-satellite receive station are shown in Table D-38 and Figure D-38.

**Table D-38. Fairbanks Protection Distances**

Number of Iterations	Minimum Distance (km)	Mean Distance (km)	Maximum Distance (km)
1	80	80	80
10	79	79.7	81
100	79	79.6	81
500	73	79.7	81

## Appendix 7

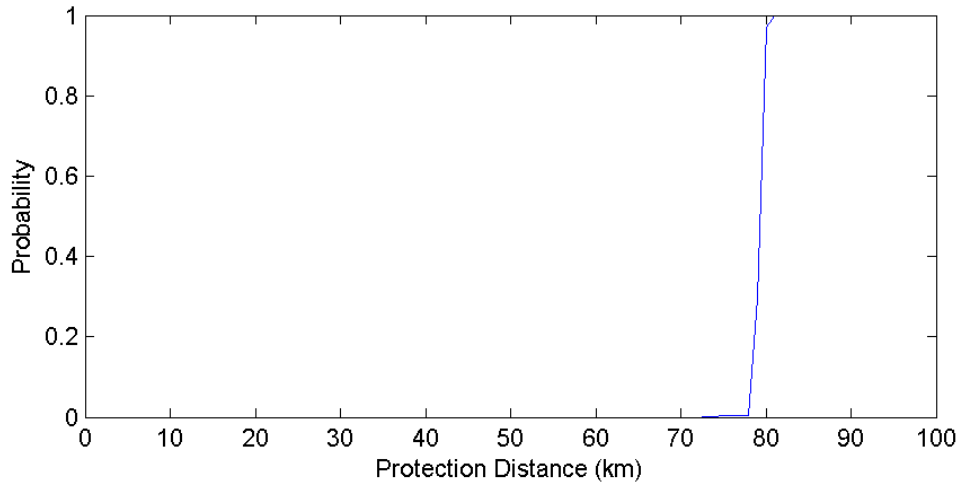
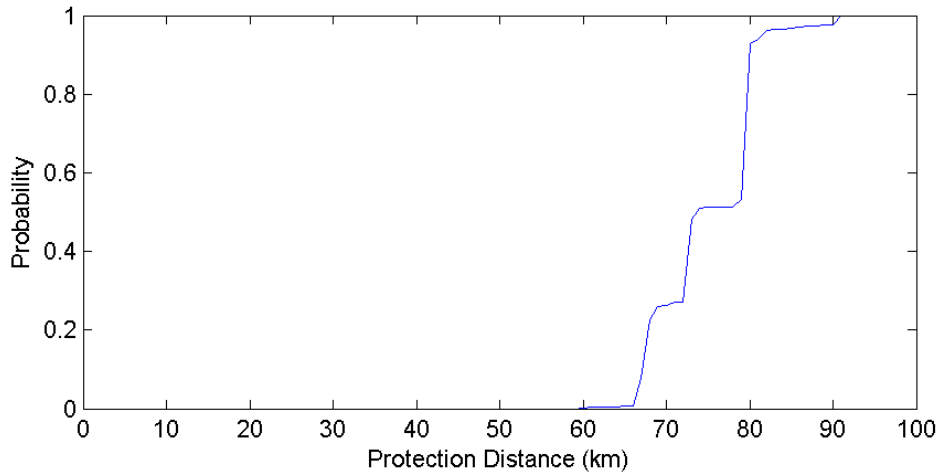

**Figure D-38. Fairbanks Protection Distances (500 Iterations)**

The protection distances for the Suitland meteorological-satellite receive station are shown in Table D-39 and Figure D-39.

**Table D-39. Suitland Protection Distances**

Number of Iterations	Minimum Distance (km)	Mean Distance (km)	Maximum Distance (km)
1	61	61	61
10	61	72	80
100	61	75.2	91
500	60	75.6	91
1000	60	75.4	91



**Figure D-39. Suitland Protection Distances (1000 Iterations)**

## Appendix 7

The protection distances for the Miami meteorological-satellite receive station are shown in Table D-40 and Figure D-40.

**Table D-40. Miami Protection Distances**

Number of Iterations	Minimum Distance (km)	Mean Distance (km)	Maximum Distance (km)
1	46	46	46
10	46	46	46
100	40	45.6	46
500	40	45.6	46

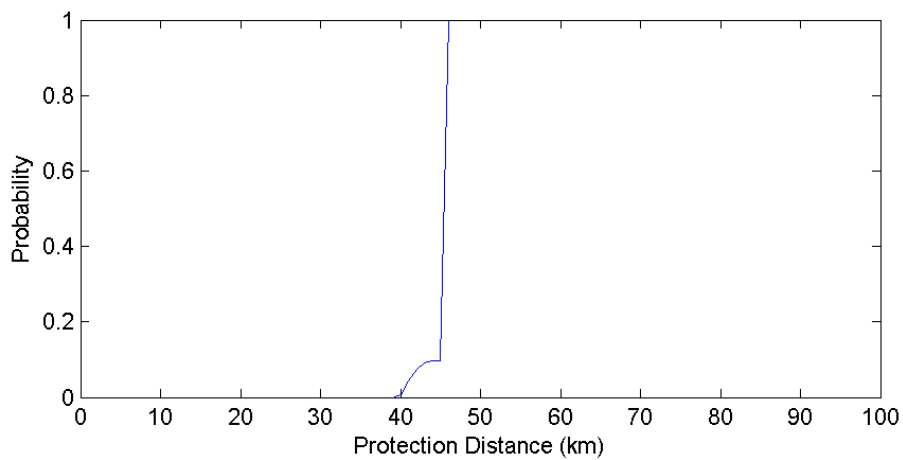

**Figure D-40. Miami Protection Distances (500 Iterations)**

The protection distances for the Ford Island/Pearl Harbor meteorological-satellite receive station are shown in Table D-41 and Figure D-41.

**Table D-41. Ford Island/Pearl Harbor Protection Distances**

Number of Iterations	Minimum Distance (km)	Mean Distance (km)	Maximum Distance (km)
1	25	25	25
10	23	24.8	25
100	23	24.9	25
500	23	24.8	25

## Appendix 7

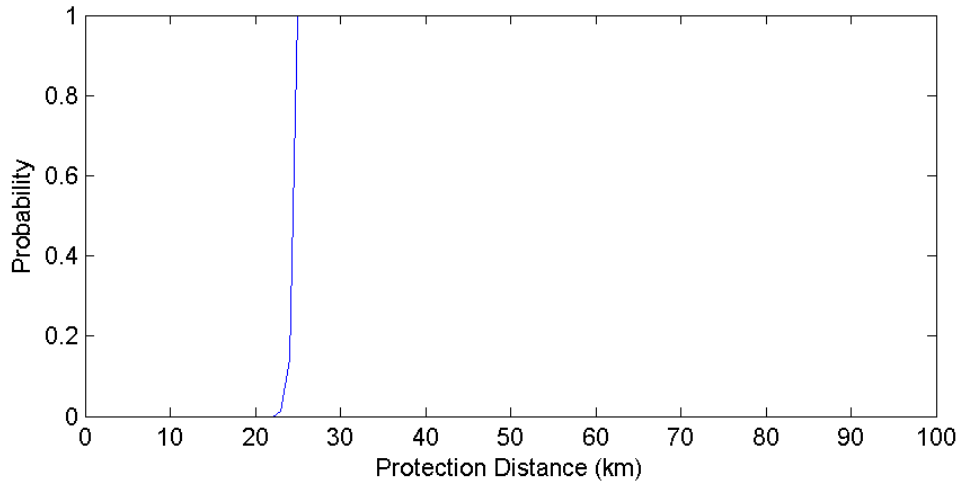
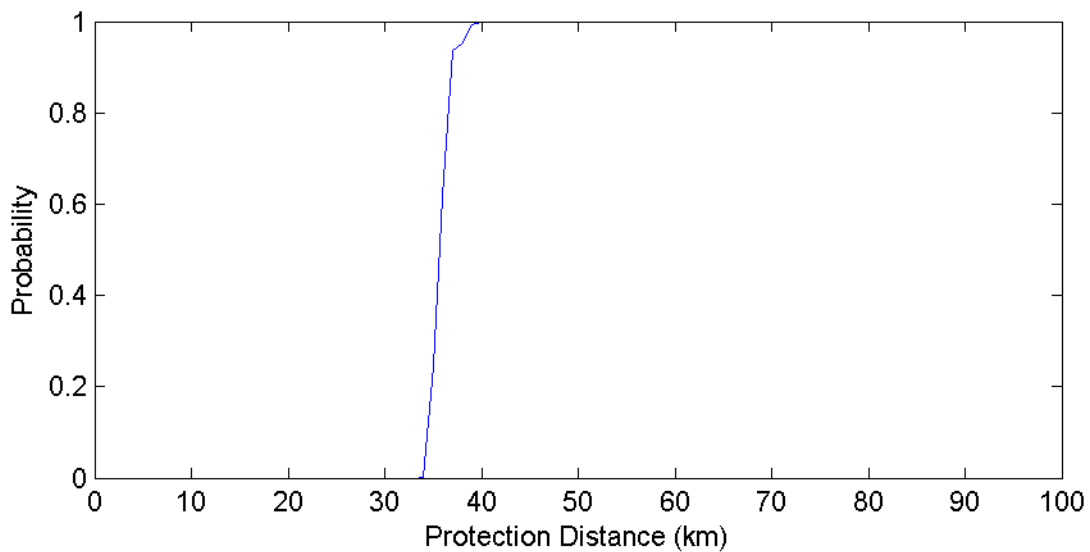

**Figure D-41. Ford Island/Pearl Harbor Protection Distances (500 Iterations)**

The protection distances for the Sioux Falls meteorological-satellite receive station are shown in Table D-42 and Figure D-42.

**Table D-42. Sioux Falls Protection Distances**

Number of Iterations	Minimum Distance (km)	Mean Distance (km)	Maximum Distance (km)
1	37	37	37
10	35	36.3	39
100	34	36.2	40
500	34	36.3	42



**Figure D-42. Sioux Falls Protection Distances (500 Iterations)**

## Appendix 7

The protection distances for the Cincinnati meteorological-satellite receive station are shown in Table D-43 and Figure D-43.

**Table D-43. Cincinnati Protection Distances**

Number of Iterations	Minimum Distance (km)	Mean Distance (km)	Maximum Distance (km)
1	27	27	27
10	24	26.2	28
100	19	26.2	32
500	19	26.3	32

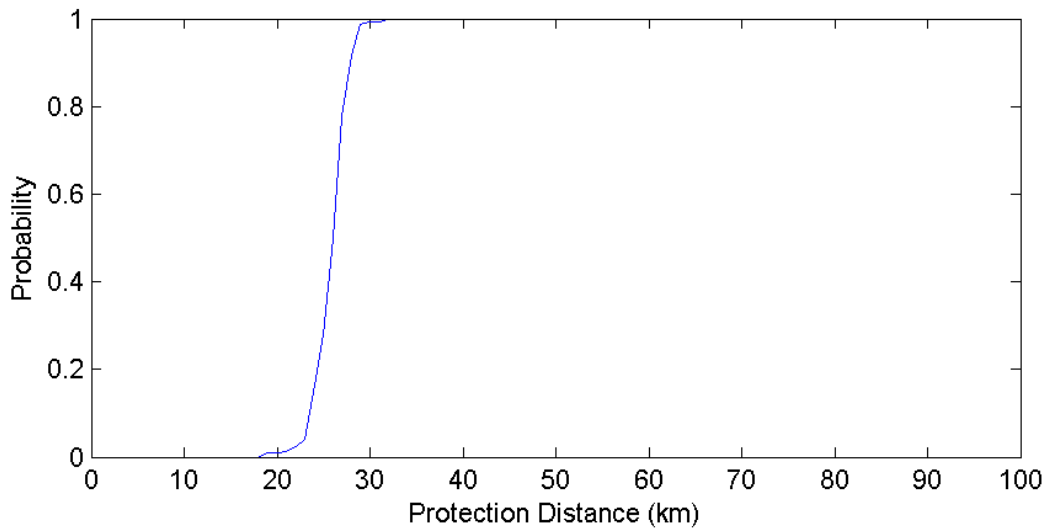

**Figure D-43. Cincinnati Protection Distances (500 Iterations)**

The protection distances for the Rock Island meteorological-satellite receive station are shown in Table D-44 and Figure D-44.

**Table D-44. Rock Island Protection Distances**

Number of Iterations	Minimum Distance (km)	Mean Distance (km)	Maximum Distance (km)
1	8	8	8
10	6	8.1	9
100	5	7.9	10
500	5	7.9	19

## Appendix 7

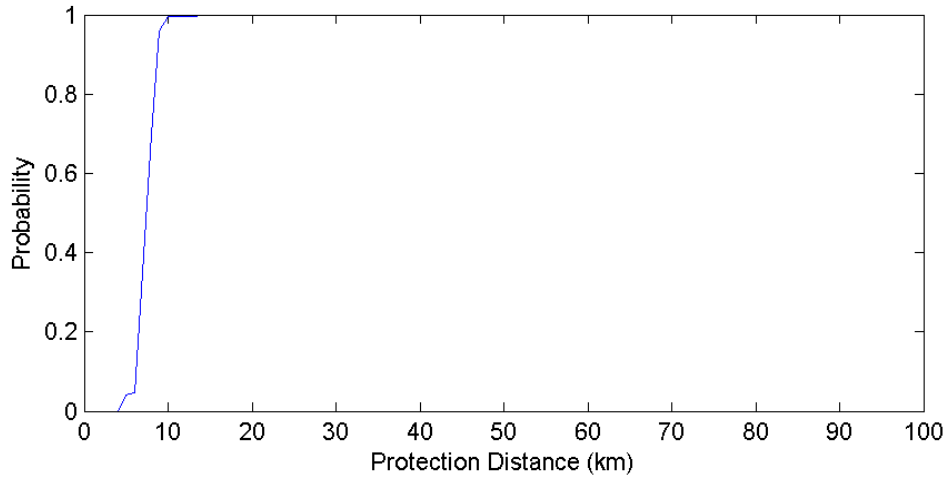
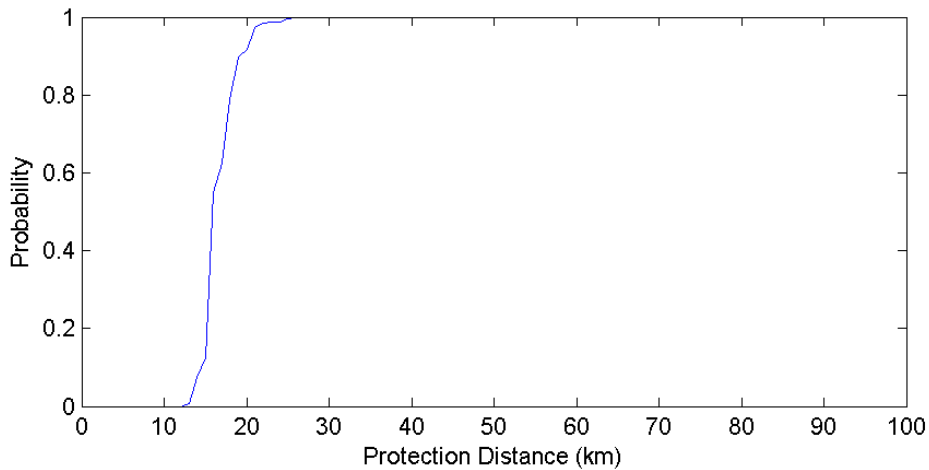

**Figure D-44. Rock Island Protection Distances (500 Iterations)**

The protection distances for the Saint Louis meteorological-satellite receive station are shown in Table D-45 and Figure D-45.

**Table D-45. Saint Louis Protection Distances**

Number of Iterations	Minimum Distance (km)	Mean Distance (km)	Maximum Distance (km)
1	18	18	18
10	14	16.6	19
100	14	16.9	22
500	13	17.1	29



**Figure D-45. Saint Louis Protection Distances (500 Iterations)**

## Appendix 7

The protection distances for the Vicksburg meteorological-satellite receive station are shown in Table D-46 and Figure D-46.

**Table D-46. Vicksburg Protection Distances**

Number of Iterations	Minimum Distance (km)	Mean Distance (km)	Maximum Distance (km)
1	10	10	10
10	7	9.3	12
100	6	9.4	14
500	6	9.6	15

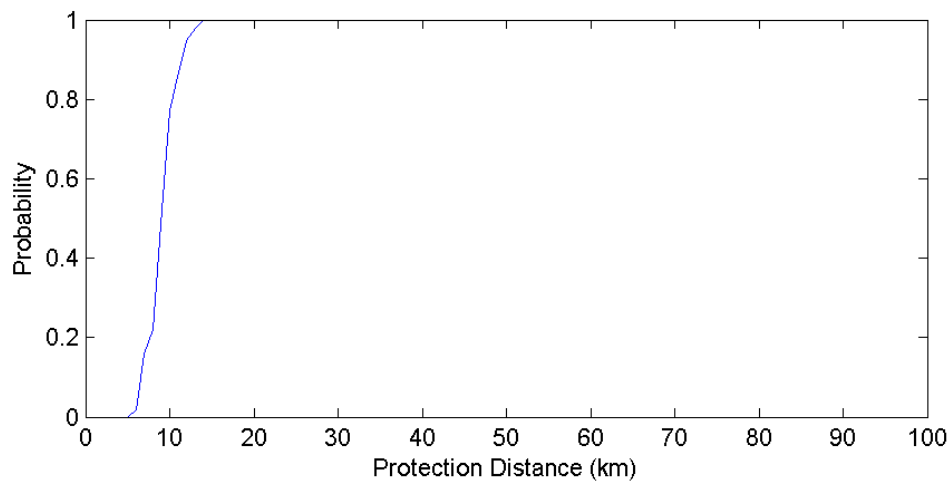

**Figure D-46. Vicksburg Protection Distances (500 Iterations)**

The protection distances for the Omaha meteorological-satellite receive station are shown in Table D-47 and Figure D-47.

**Table D-47. Omaha Protection Distances**

Number of Iterations	Minimum Distance (km)	Mean Distance (km)	Maximum Distance (km)
1	28	28	28
10	16	26.3	30
100	12	23.2	30
500	12	23.1	30

## Appendix 7

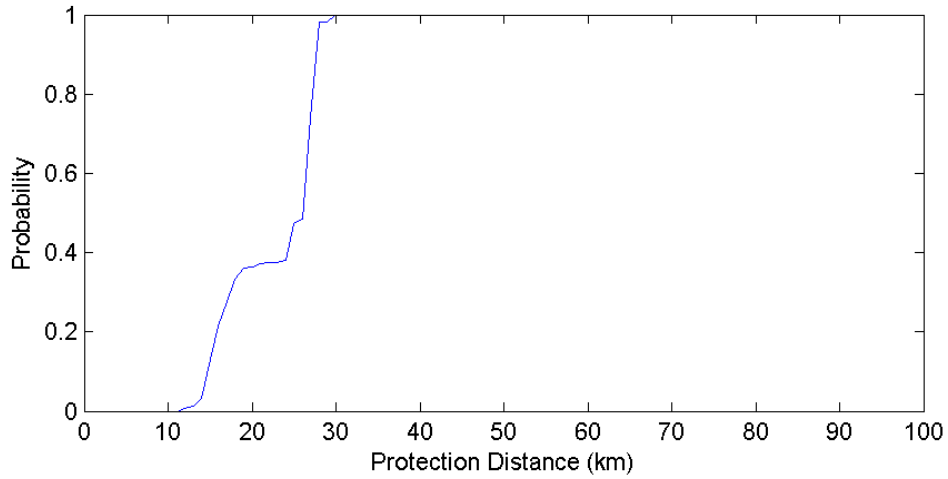
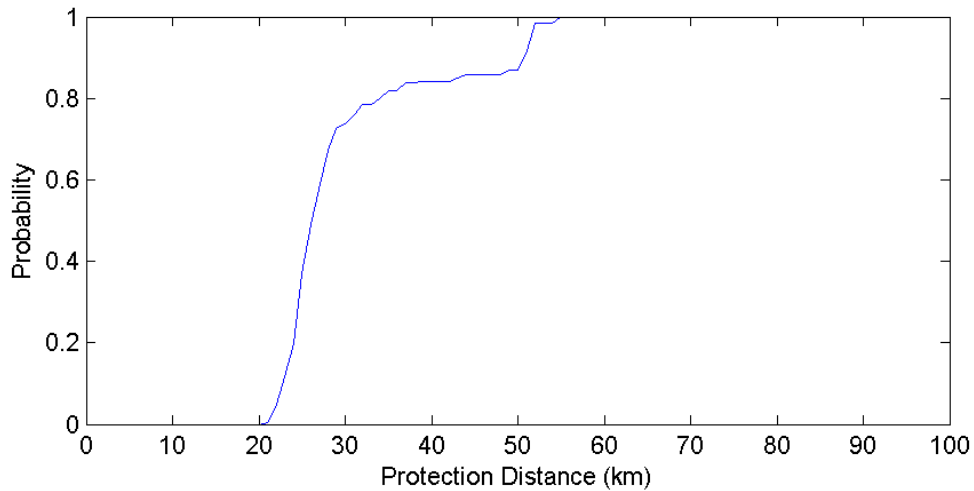

**Figure D-47. Omaha Protection Distances (500 Iterations)**

The protection distances for the Cincinnati meteorological-satellite receive station are shown in Table D-48 and Figure D-48.

**Table D-48. Sacramento Protection Distances**

Number of Iterations	Minimum Distance (km)	Mean Distance (km)	Maximum Distance (km)
1	35	35	35
10	22	26.7	35
100	21	30.3	55
500	21	30.5	55



**Figure D-48. Sacramento Protection Distances (500 Iterations)**



## Appendix 7

The protection distances for the Elmendorf meteorological-satellite receive station are shown in Table D-49 and Figure D-49.

**Table D-49. Elmendorf Protection Distances**

Number of Iterations	Minimum Distance (km)	Mean Distance (km)	Maximum Distance (km)
1	14	14	14
10	14	14	14
100	13	13.99	14
500	13	13.97	14

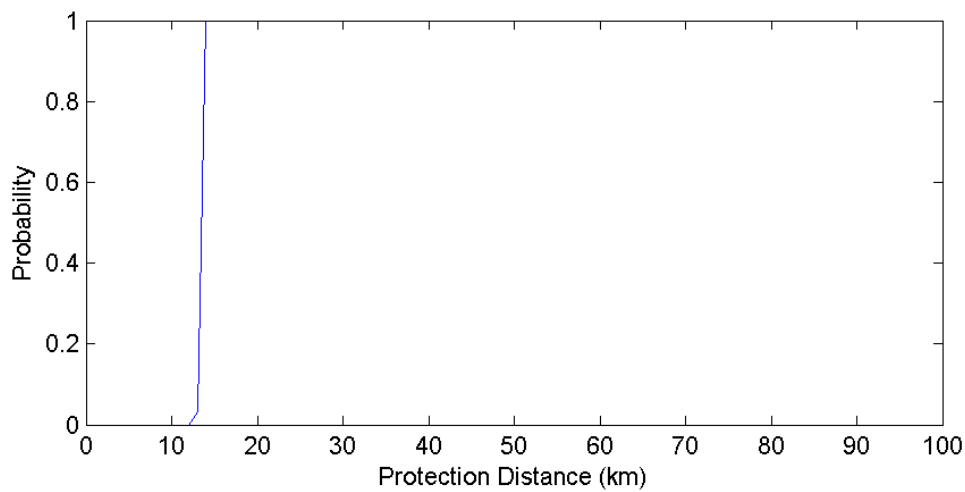

**Figure D-49. Elmendorf Protection Distances (500 Iterations)**

The protection distances for the Monterey meteorological-satellite receive station are shown in Table D-50 and Figure D-50.

**Table D-50. Monterey Protection Distances**

Number of Iterations	Minimum Distance (km)	Mean Distance (km)	Maximum Distance (km)
1	85	85	85
10	83	84.2	85
100	72	83.9	85
500	72	83.9	85

## Appendix 7

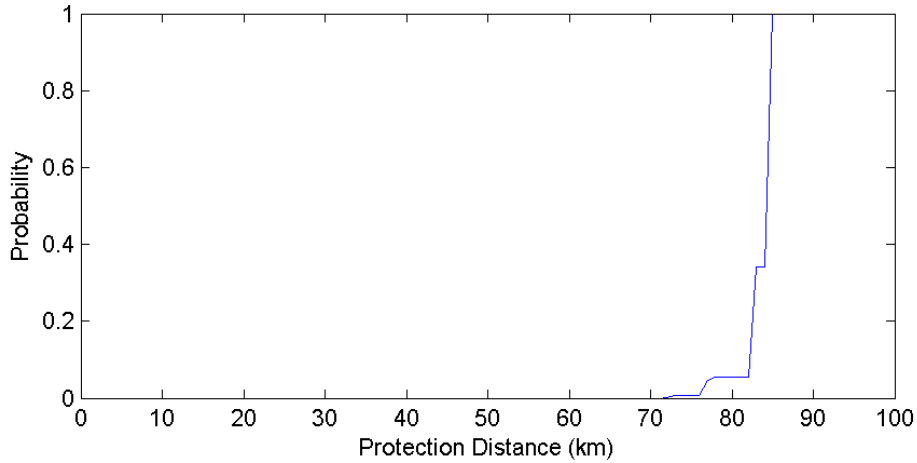
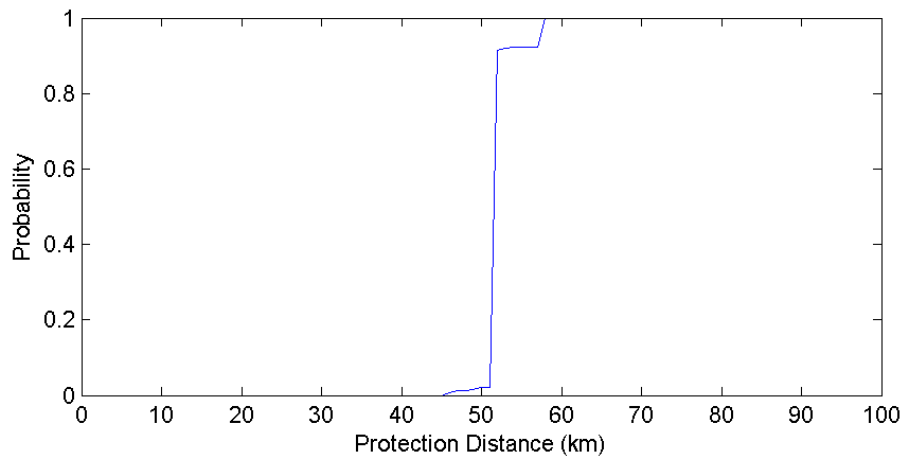

**Figure D-50. Monterey Protection Distances (500 Iterations)**

The protection distances for the Stennis meteorological-satellite receive station are shown in Table D-51 and Figure D-51.

**Table D-51. Stennis Protection Distances**

Number of Iterations	Minimum Distance (km)	Mean Distance (km)	Maximum Distance (km)
1	52	52	52
10	46	51.2	52
100	46	52.2	58
500	46	52.4	58



**Figure D-51. Stennis Protection Distances (500 Iterations)**

The protection distances for the Twenty-Nine Palms meteorological-satellite receive station are shown in Table D-52 and Figure D-52.

## Appendix 7

**Table D-52. Twenty-Nine Palms Protection Distances**

Number of Iterations	Minimum Distance (km)	Mean Distance (km)	Maximum Distance (km)
1	77	77	77
10	57	75.2	80
100	52	73	80
500	51	72.7	80

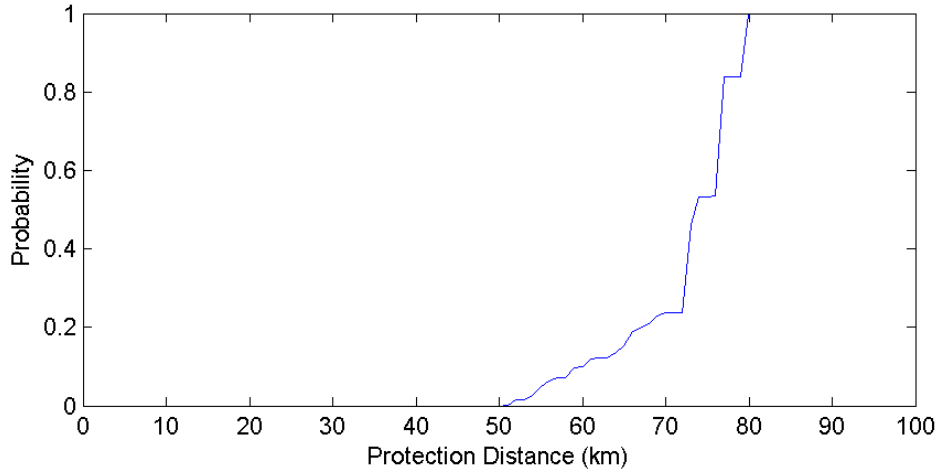

**Figure D-52. Twenty-Nine Palms Protection Distances (500 Iterations)**

The protection distances for the Yuma meteorological-satellite receive station are shown in Table D-53 and Figure D-53.

**Table D-53. Yuma Protection Distances**

Number of Iterations	Minimum Distance (km)	Mean Distance (km)	Maximum Distance (km)
1	94	94	94
10	70	78.7	94
100	70	79.2	95
500	70	79.3	95

## Appendix 7

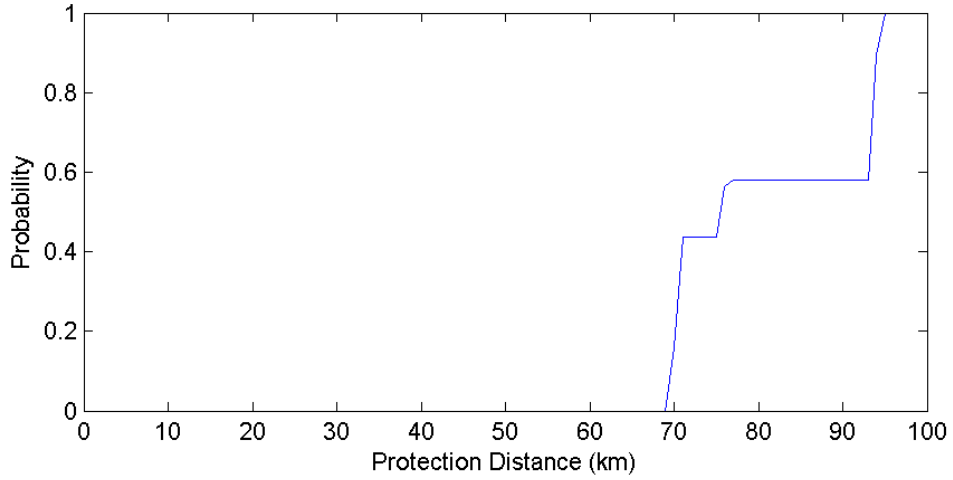

**Figure D-53. Yuma Protection Distances (500 Iterations)**

The protection distances for the Anderson meteorological-satellite receive station are shown in Table D-54.

**Table D-54. Anderson Protection Distances**

<b>Number of Iterations</b>	<b>Minimum Distance (km)</b>	<b>Mean Distance (km)</b>	<b>Maximum Distance (km)</b>
1	42	42	42
10	37	39.5	42
100	37	39.5	42
500	37	39.5	42

# Appendix 8

## Working Group 1 Participants

### **Co-Chairs**

Ivan Navarro – NOAA  
Steve Sharkey – T-Mobile

### **CSMAC Liaisons**

Dennis Roberson – Roberson and Associates  
Mark McHenry – Shared Spectrum

### **NTIA Liaisons**

Edward Drocella  
John Hunter

### **FCC Liaisons**

Robert Weller - FCC  
Navid Golshahi - FCC  
Chris Helzer - FCC  
Michael Ha - FCC  
Robert Pavlak – FCC  
Janet Young – FCC

### **Participants**

Alex "Buzz" Merrill – The Aerospace Corporation  
Alexander Gerdenitsch – Motorola  
Art Deleon – Marine Corp  
Beau Backus – The Aerospace Corporation  
Bill Pepper – Harris Corporation  
Bob Martin – Alion Science  
Brian Ramsay – Mitre  
Bryan L. Wright – Department of Interior  
Carol Swan – Air Force  
Chip Yorkgitis – Kelley Drye  
Chris Wieczorek – T-Mobile  
Colonel Donald Reese – Air Force  
Colin Alberts - Freedom Technologies, Inc.  
Dave Olaker – Harris Corporation  
David G. Steer - RIM  
David Lubar – Raytheon  
David Reed – Air Force  
David S. Greenberg – Alion Science  
Doug McGinnis – Exelon Corporation  
Doug Smith - Lightsquared  
Douglas Duet – AT&T  
Eric Nelson - NTIA  
Fred Moorefield – Air Force  
Gerald Hurt – ITT Exelis  
Grace Hu - OMB

## Appendix 8

Gregory Formosa - Army  
J.H. "Jim" Snider - Isolon  
Janice Obuchowski - Freedom Technologies, Inc.  
Jason M Greene – Alion Science  
Jason Straughan – Army  
Jeff Marks – Alcatel-Lucent  
Joe Giangrosso – Air Force  
Johnnie Best - Navy  
Jorgen Karlsson - Ericsson  
Juan Deaton - Idaho National Laboratory  
Ken Stowe - Navy  
Ken Zdunek - Roberson and Associates  
Kumar Balachandran – Ericsson  
Lawrence Lambert - ITT Exelis  
LCDR Frank Price - Navy  
Lily Zeleke – Office of the Secretary of Defense  
Lieutenant Colonel Lori Winn – Air Force  
Lieutenant Colonel Troy Orwan - Office of the Secretary of Defense  
Lloyd Apirion – NOAA  
Lynna McGrath - Office of the Secretary of Defense  
Maqbool Aliani - Lightsquared  
Mark Johnson - Navy  
Mark Mulholland - NOAA  
Mark Paese - NOAA  
Mark Racek - Ericsson  
Mark Uncapher - TIA  
Maurice B Winn – Alion Science  
Mike Chartier - Intel  
O. Alden Smith - DoD  
Paul Frew - RIM  
Paul Mckenna - NTIA  
Paul Sinderbrand - Wilkinson Barker Knauer, LLP  
Peter G Kim - The Aerospace Corporation  
Philip F. Baummer - Alion Science  
Pierre Missud - ATDI  
Rangam Subramanian - Idaho National Laboratory  
Rich DeSalvo – DoD  
Richard A Cote CTR USAF AF/A3SO – Air Force  
Robert Hauser – Air Force  
Robert Kubik - Samsung  
Ron Kindelberger - Navy  
Stephen Wilkus – Alcatel-Lucent  
Stevan Jovancevic - DoD  
Thomas Moore – Air Force  
Tom Dombrowsky - Wiley Rein  
Tom Kidd - Navy  
Nelson Ueng - T-Mobile